

# Processos bioelectroquímics

**Sebastià Puig**

[sebastia.puig@udg.edu](mailto:sebastia.puig@udg.edu)

X @sebastia.puig

in sebastia-puig

## Acknowledgements (selected):

# Microbial Electrosynthesis

**CO<sub>2</sub> Recycling** **Bioremediation** **Bioelectrochemistry**

**Wastewater Treatment** **Circular Economy** **Resource Recovery** **Biofuels**

**Nitrate Removal** **Pattern Discovery** **Microbial Proteins** **Machine Learning** **Electromicrobiology**

**Methane Production**

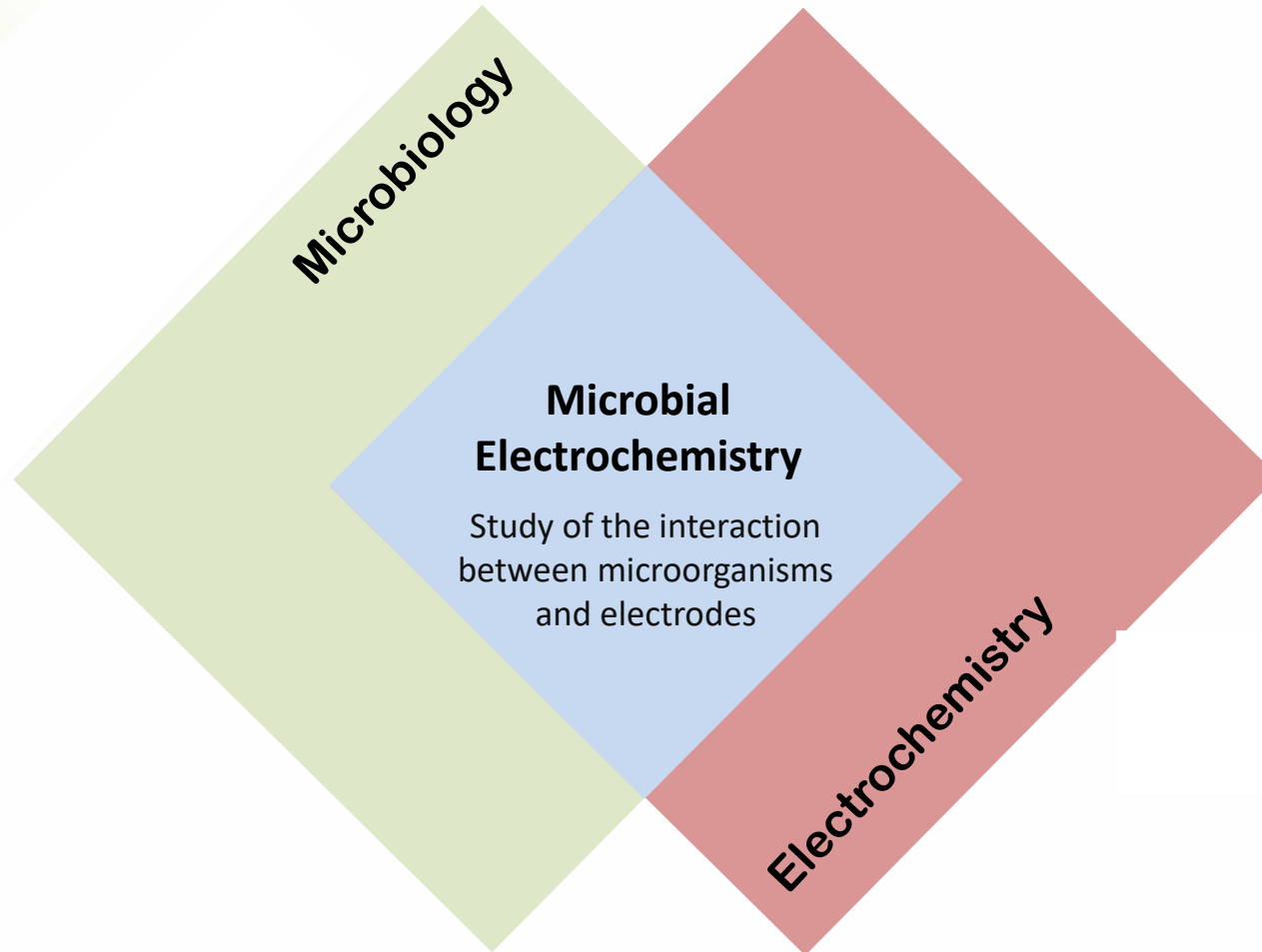

**Microbial Electrochemical Technologies  
METs**

Courtesy of Abraham Nuñez-Esteve

J Solid State Electrochem (2011) 15:1481–1486  
DOI 10.1007/s10008-011-1395-7

REVIEW

## Discover the possibilities: microbial bioelectrochemical systems and the revival of a 100-year-old discovery

Uwe Schröder

*Electrical Effects accompanying the Decomposition of Organic Compounds.*

By M. C. POTTER, Sc.D., M.A., Professor of Botany in the University of Durham.

(Communicated by Dr. A. D. Waller, F.R.S. Received July 14, 1911.)

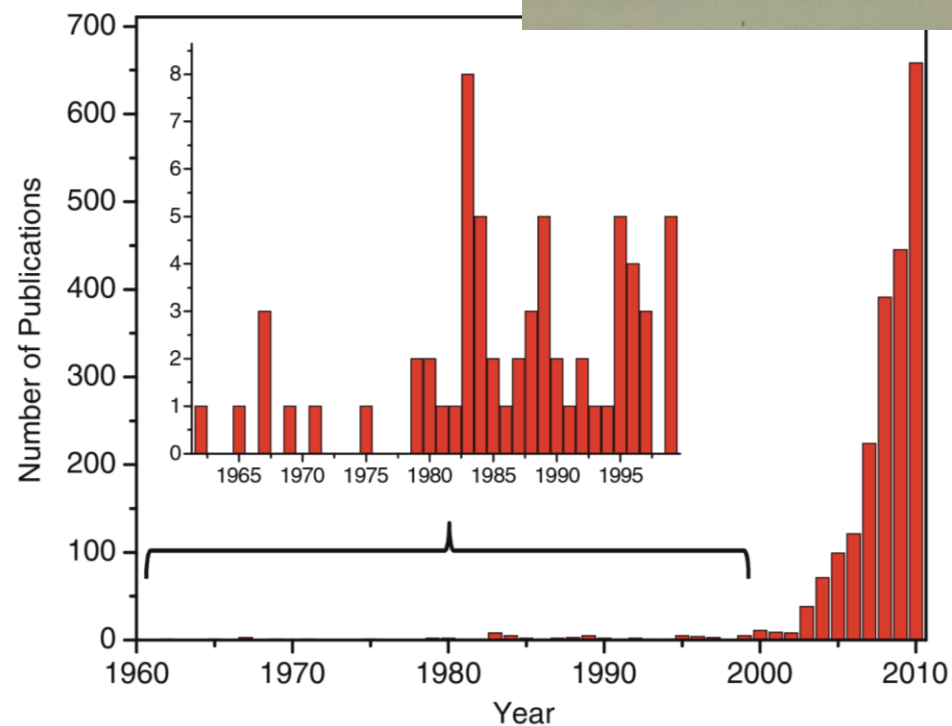

**Fig. 1** Number of publications from 1960 to 2010 containing the phrase “microbial fuel cell” (SciFinderScholar, February 2011)

Bioresource Technology 347 (2022) 126705



ELSEVIER

Contents lists available at ScienceDirect

Bioresource Technology

journal homepage: [www.elsevier.com/locate/biortech](http://www.elsevier.com/locate/biortech)

Review

### Let's chat: Communication between electroactive microorganisms

Catarina M. Paquete<sup>a</sup>, Miriam A. Rosenbaum<sup>b,c</sup>, Lluís Bañeras<sup>d</sup>, Amelia-Elena Rotaru<sup>e</sup>,  
Sebastià Puig<sup>f,\*</sup>

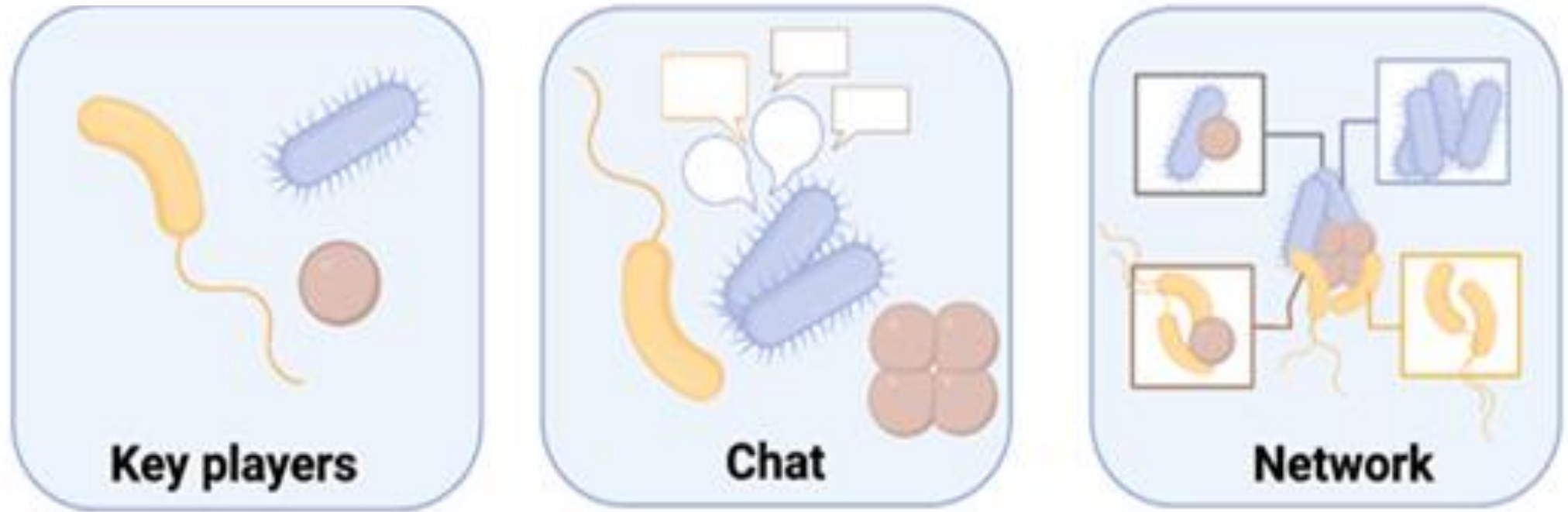

# Exoelectrogens microorganisms

# Electrotrophs microorganisms

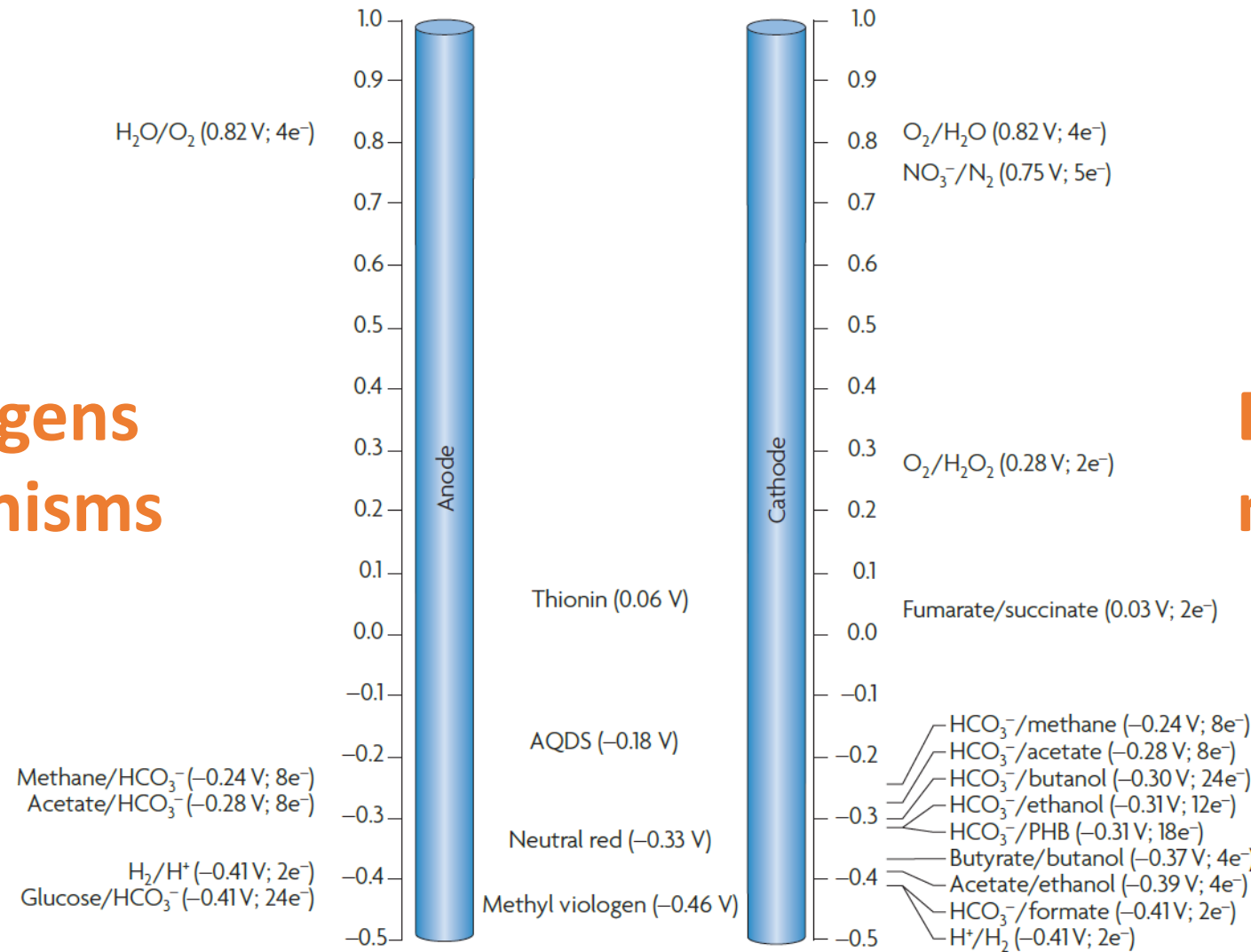

PHB, poly-β-hydroxybutyrate. \*The electrode potentials of all electron donor and acceptor couples are calculated from Gibbs free energy data, from REFS 99, 117, according to the methods described in REF. 13. The E<sub>0</sub> values of the electron mediators are from REFS 83, 118.

[Key players]

Exoelectrogens  
microorganisms

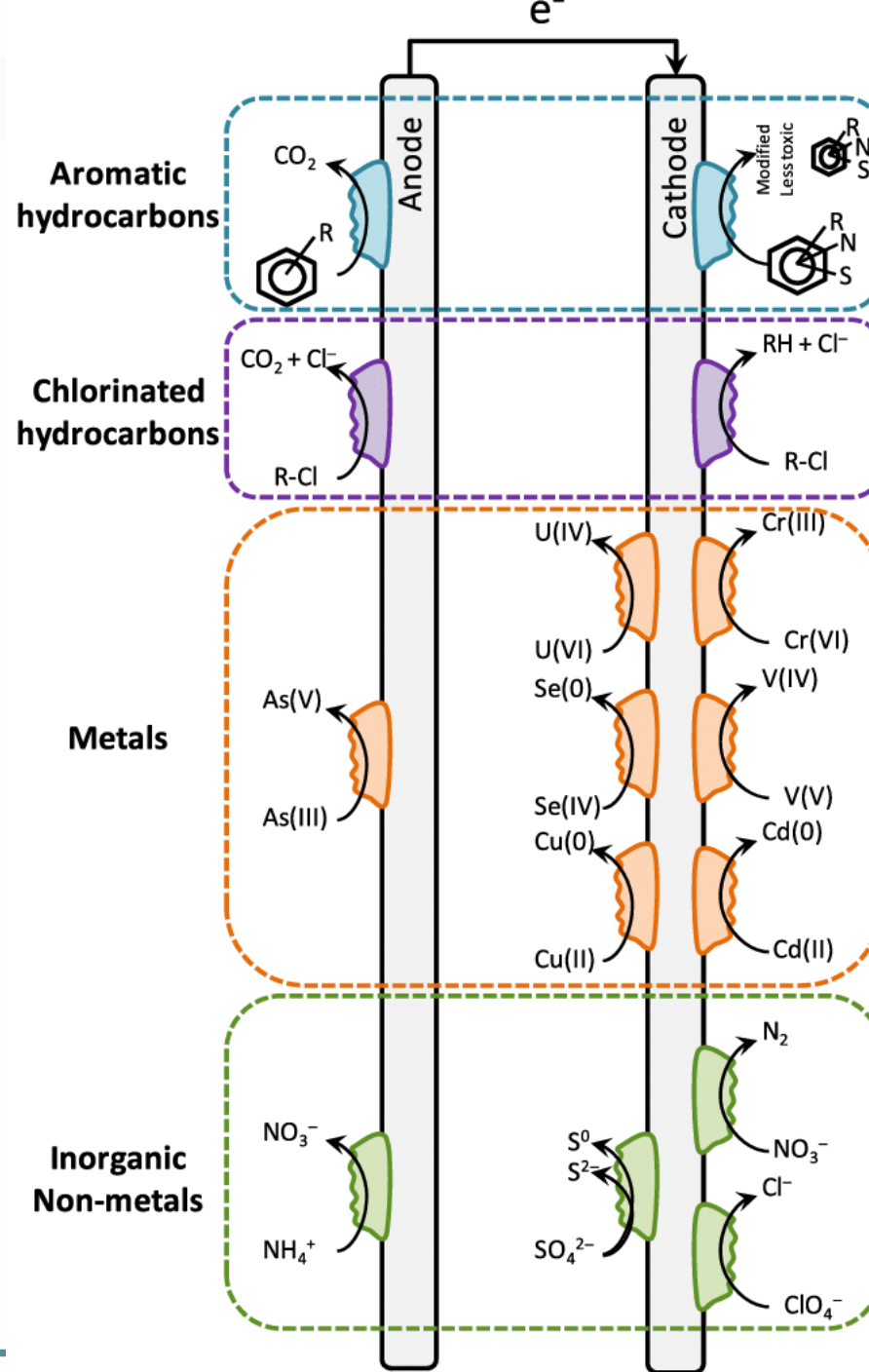

Electrotrophs  
microorganisms

Pous *et al.* (2018). Microbial Biotechnology 11(1), 119.

# Exo-electrogenic

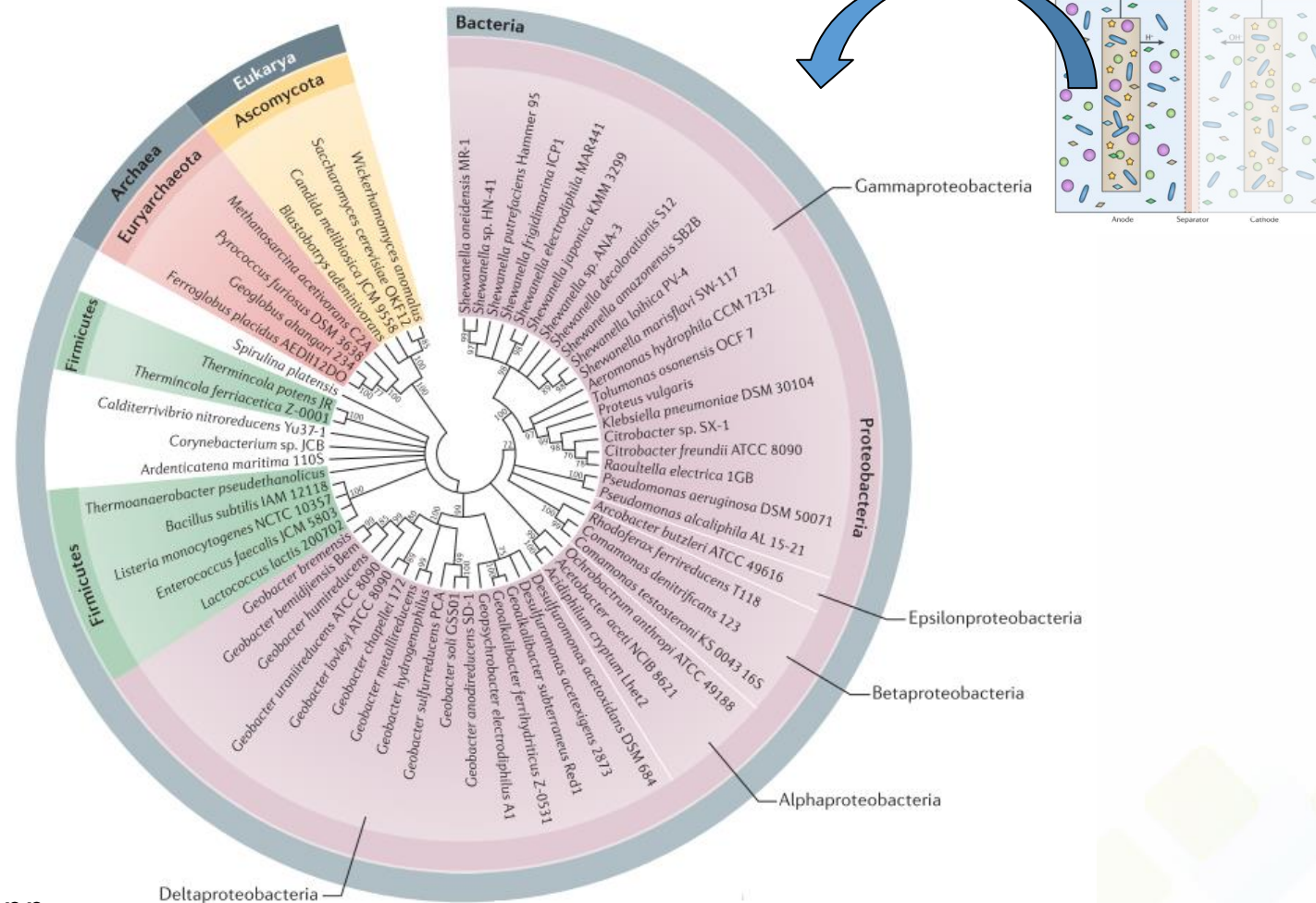

## Bacteria

- *Geobacter* spp.
- *Shewanella* spp.

## Archaea

- *Methanosarcina* spp.

Logan et al., 2019. Nature Reviews Microbiology

## Exo-electrogenic – Organic matter oxidizers

Biochar

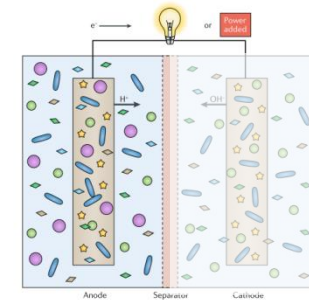

<https://www.carbongold.com/>



<https://www.gardenista.com>

An **electrotroph** is a microorganism which can receive electrons necessary for its growth from an electrode (power supply) terminal.

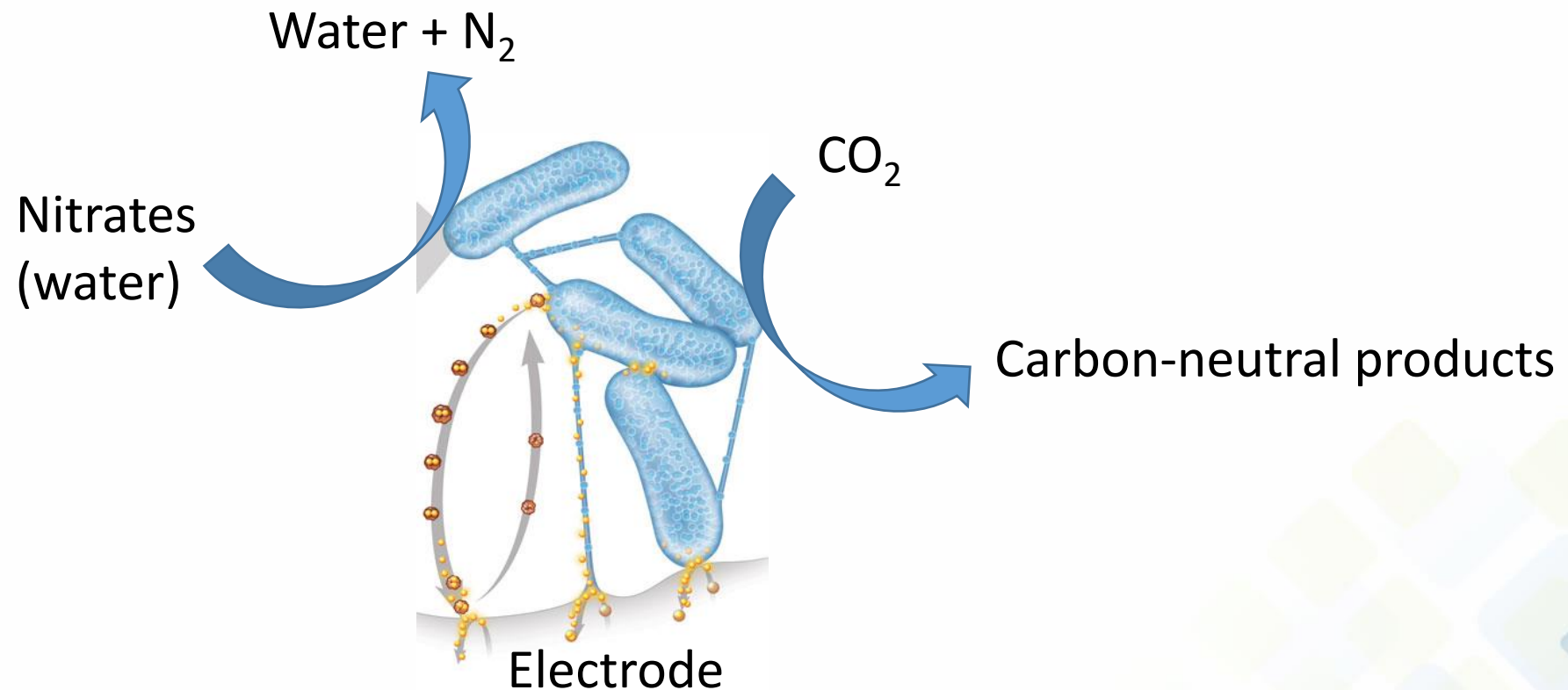



## Electrotrophs – Nitrate reducers

- Groundwater wells



shutterstock.com • 1061041094

## Electrotrophs - Methanogens

Ruminant gut  
Paddy soils  
Rice field

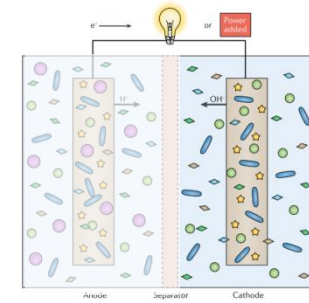

shutterstock.com • 1383828836



Bioresource Technology 347 (2022) 126705



Contents lists available at ScienceDirect

Bioresource Technology

journal homepage: [www.elsevier.com/locate/biortech](http://www.elsevier.com/locate/biortech)

Review

### Let's chat: Communication between electroactive microorganisms

Catarina M. Paquete<sup>a</sup>, Miriam A. Rosenbaum<sup>b,c</sup>, Lluís Bañeras<sup>d</sup>, Amelia-Elena Rotaru<sup>e</sup>,  
Sebastià Puig<sup>f,\*</sup>

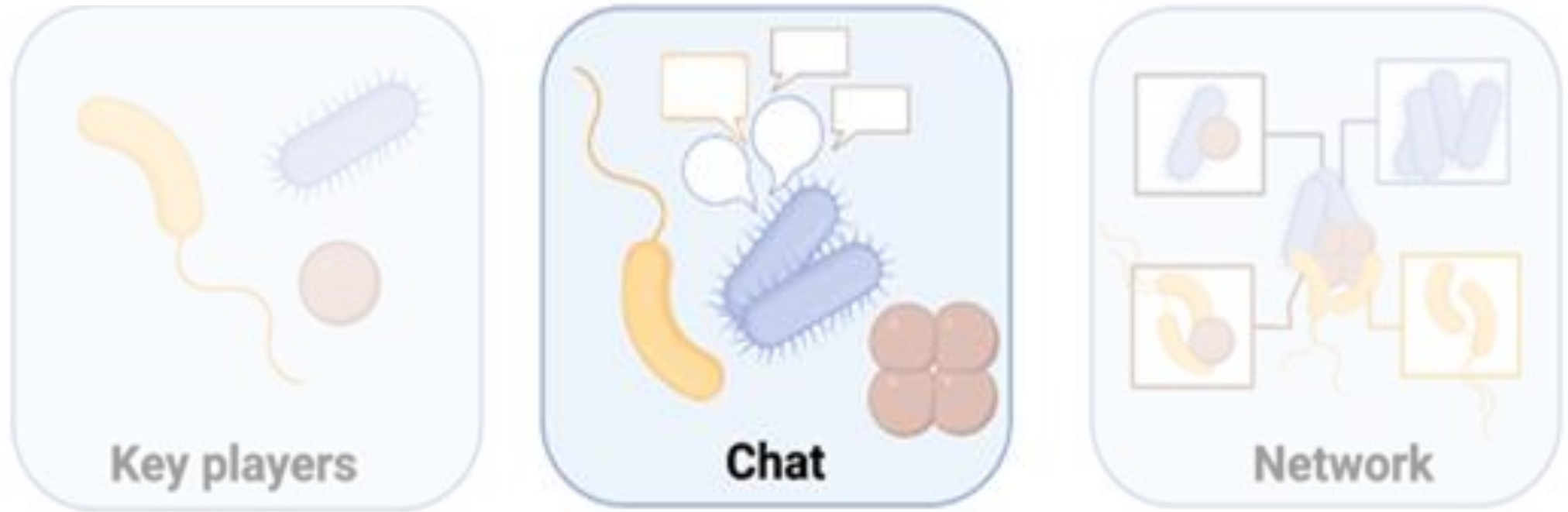

# KEY PLAYERS AND THEIR EXTRACELLULAR ELECTRON TRANSFER PROCESSES

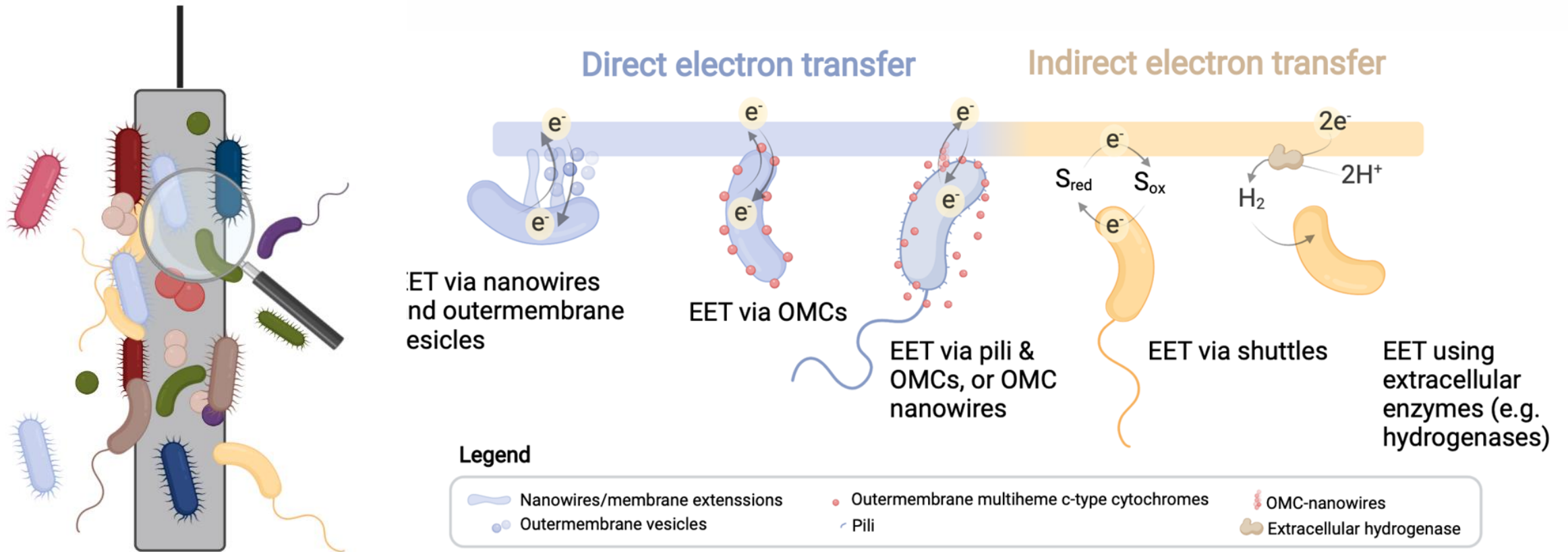

Paquete *et al.* (2022). *Bioresource Technology* 347, 126705

# The microbe-electrode interaction

## Electron transfer mechanisms

- Mediated electron transfer (a)
- Short-range electron transfer (b)
- Long-range electron transfer (c)

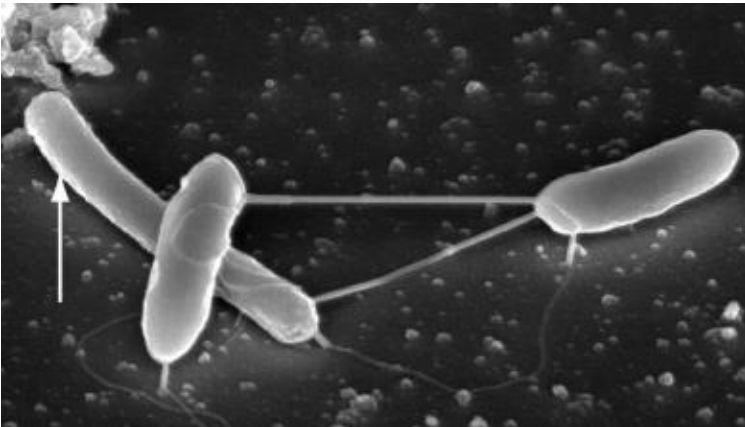

Yuri Gorby, Rensselaer Polytechnic Institute, Troy, New York

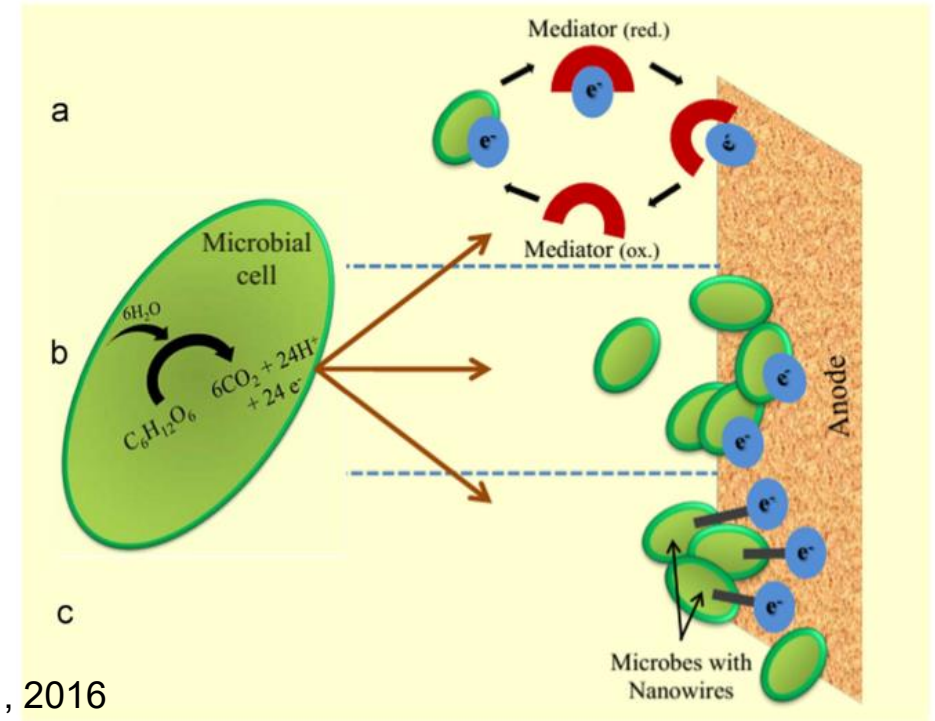

Butti et al., 2016

## Exoelectrogenic microorganisms (give electrons)

- *Geobacter*, *Shewanella*, *Thermincola*

## Electrotrophic microorganisms (uptake electrons)

- *Desulfovibrio*, *Sporomusa*, *Clostridium*

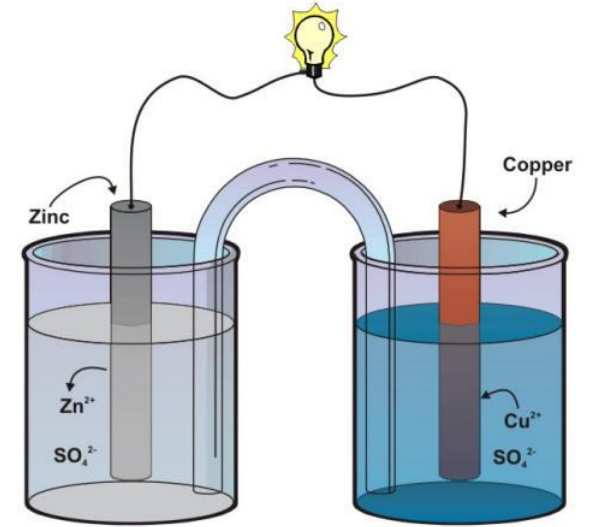
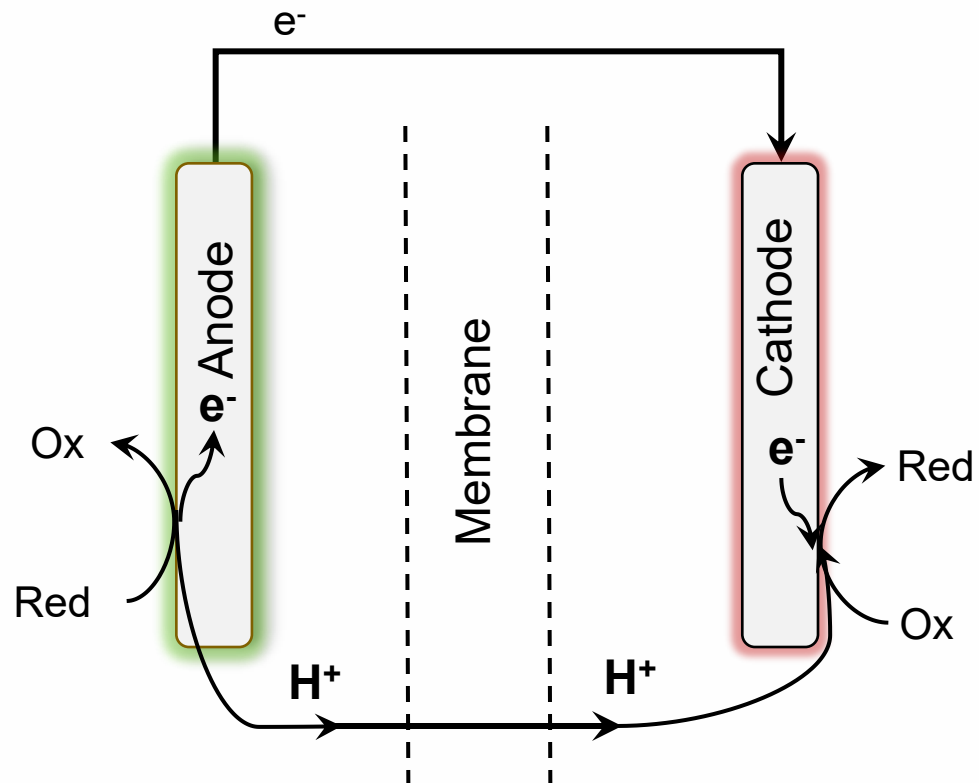

Daniel Cell



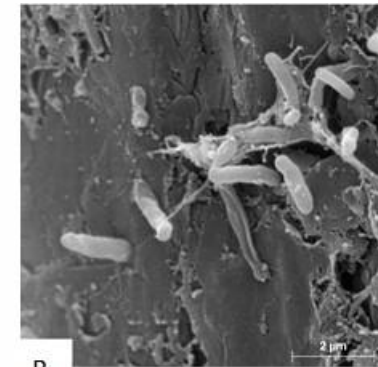
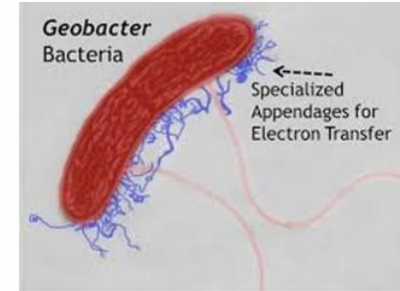
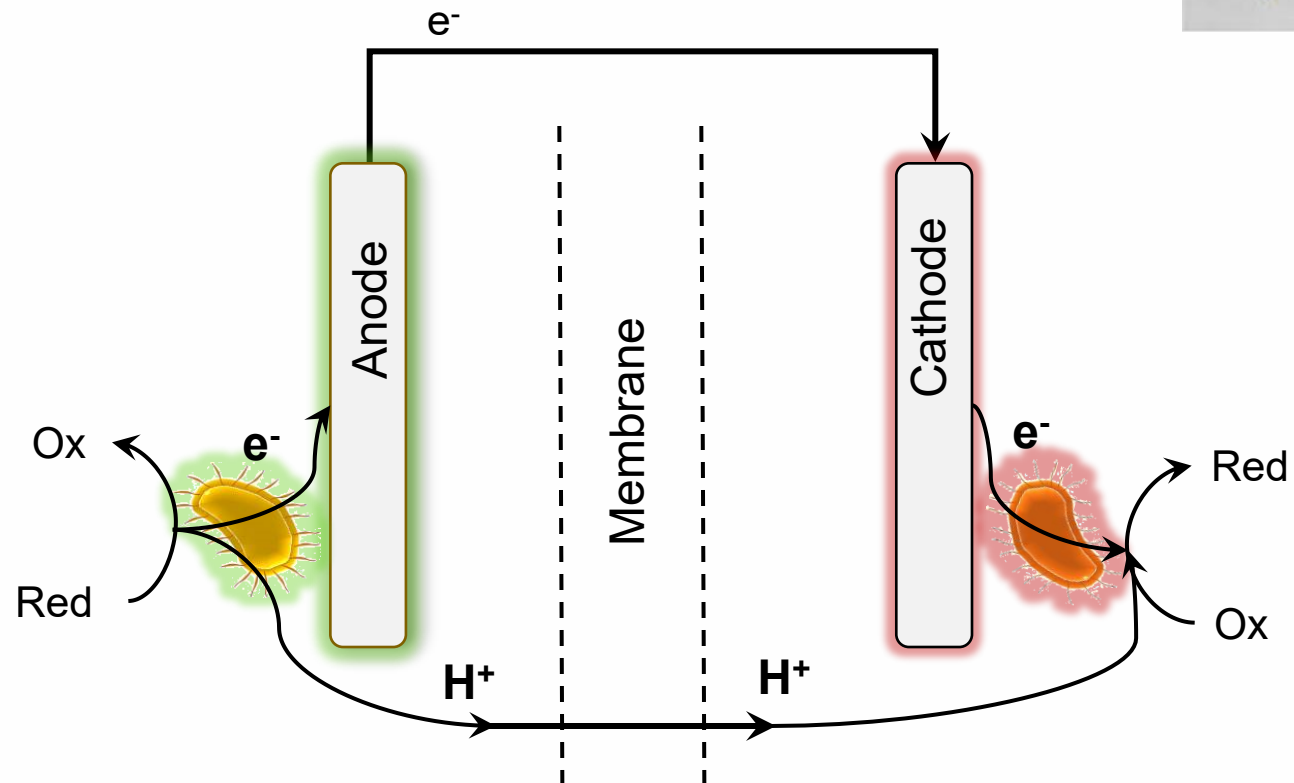

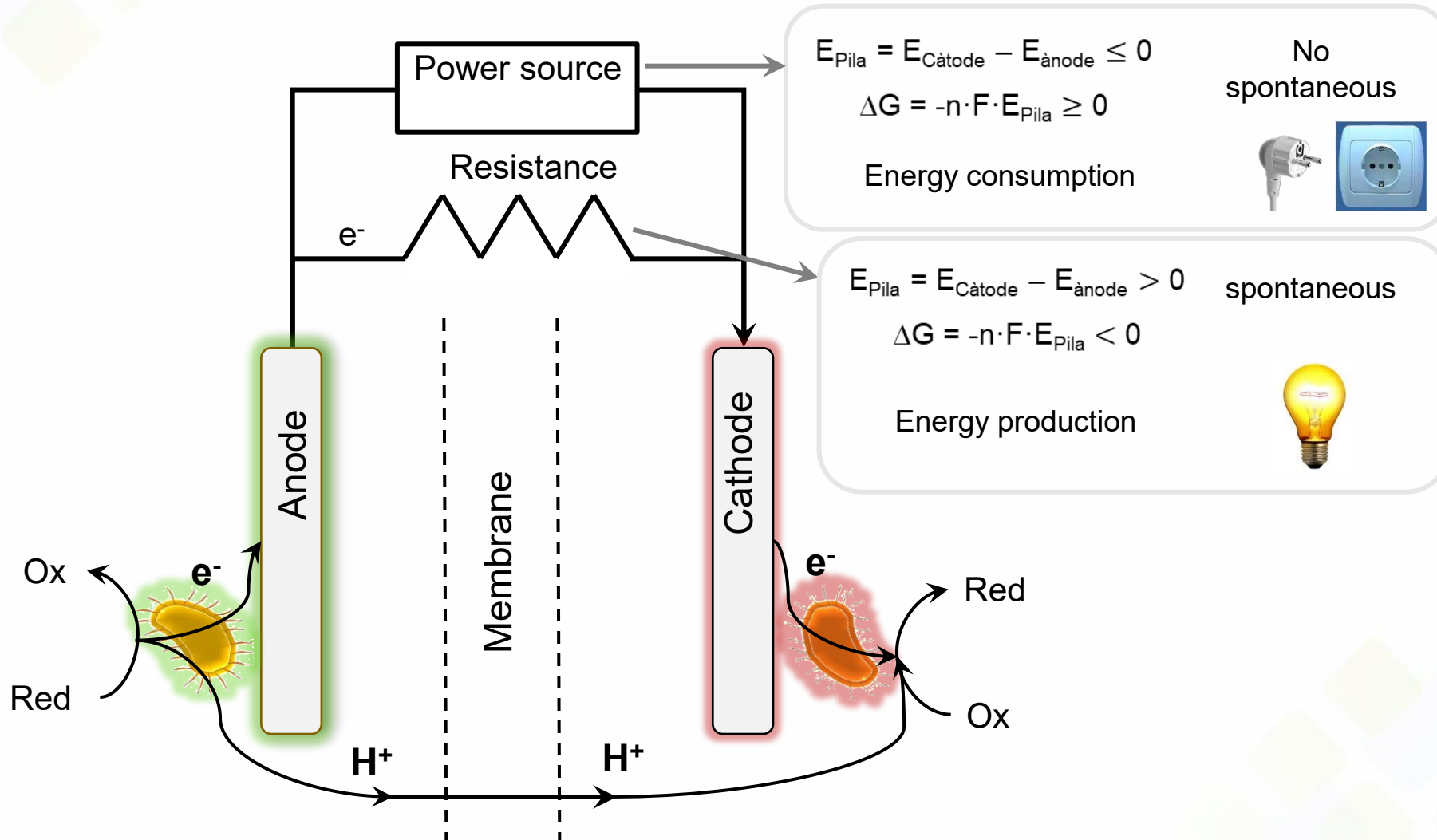

Bioresource Technology 347 (2022) 126705



ELSEVIER

Contents lists available at ScienceDirect

Bioresource Technology

journal homepage: [www.elsevier.com/locate/biortech](http://www.elsevier.com/locate/biortech)

Review

### Let's chat: Communication between electroactive microorganisms

Catarina M. Paquete<sup>a</sup>, Miriam A. Rosenbaum<sup>b,c</sup>, Lluís Bañeras<sup>d</sup>, Amelia-Elena Rotaru<sup>e</sup>,  
Sebastià Puig<sup>f,\*</sup>





## BIOREMEDIATION

### Electro-Bioremediation

Restoring water quality through the bio-electro-remediation of **nitrates** and **microplastics** in contaminated aquifers or wastewater.



## SUSTAINABLE FUELS

### Microbial Electrosynthesis

Synthesis of **methane** from (indoor) CO<sub>2</sub>, **Aviation Fuel (SAF)** from solar, and **bioethanol** from recycled carbon.



## NOVEL PRODUCTS

### Microbial Proteins

Empowering land-free protein production via continuous fermentation of **H<sub>2</sub>-oxidizing bacteria** using water, urea and electricity.

[Carbon recycling – Air recovery]

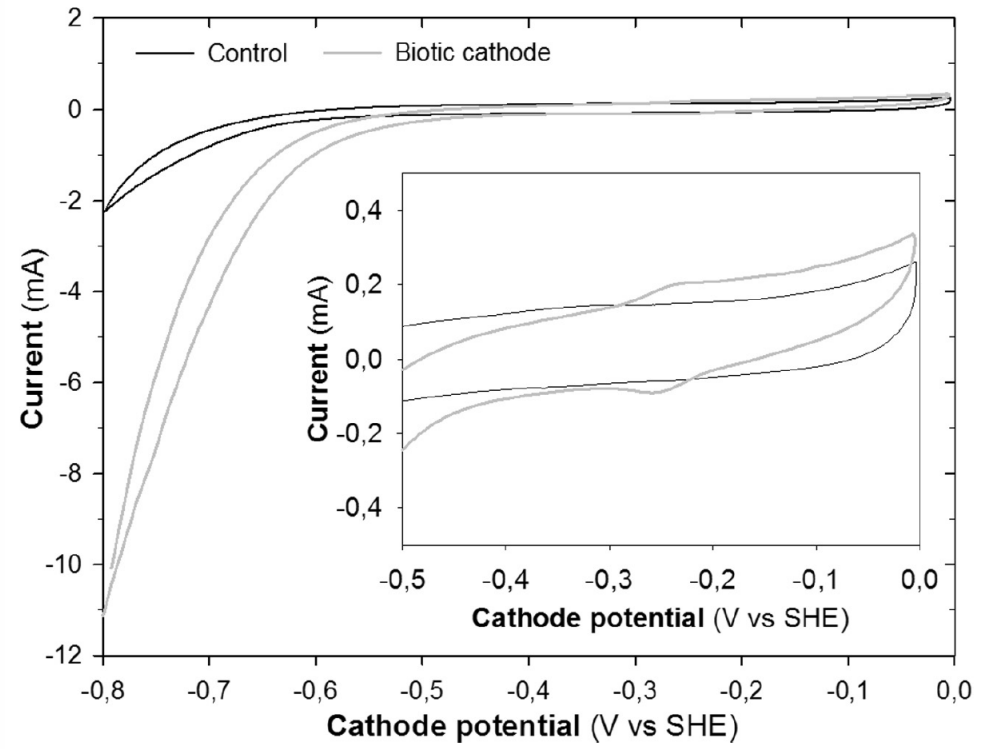
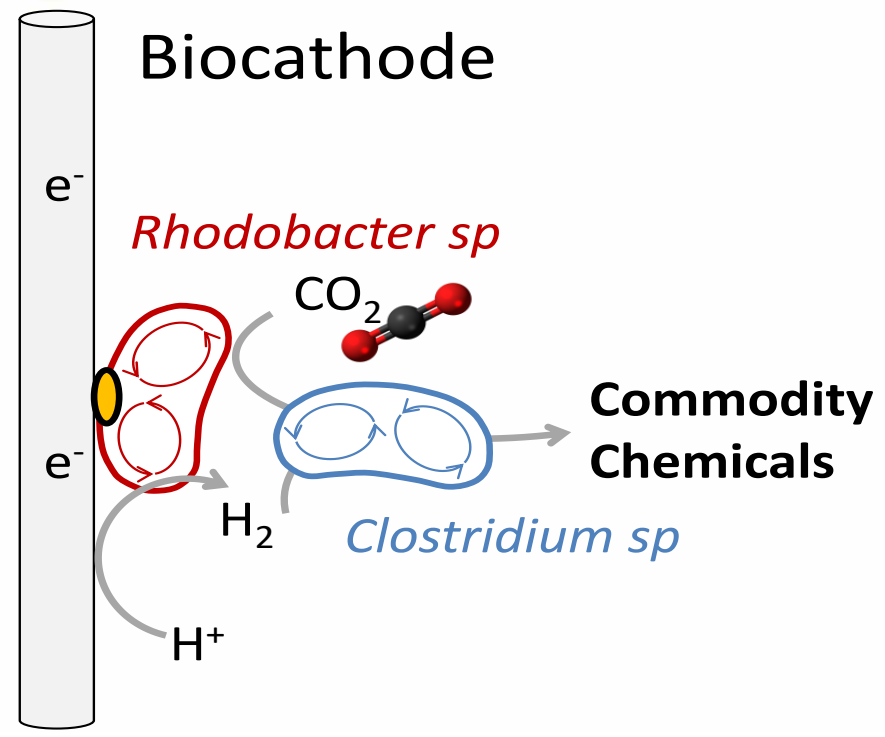

### Abiotic vs. **Biotic** mediated H<sub>2</sub> production

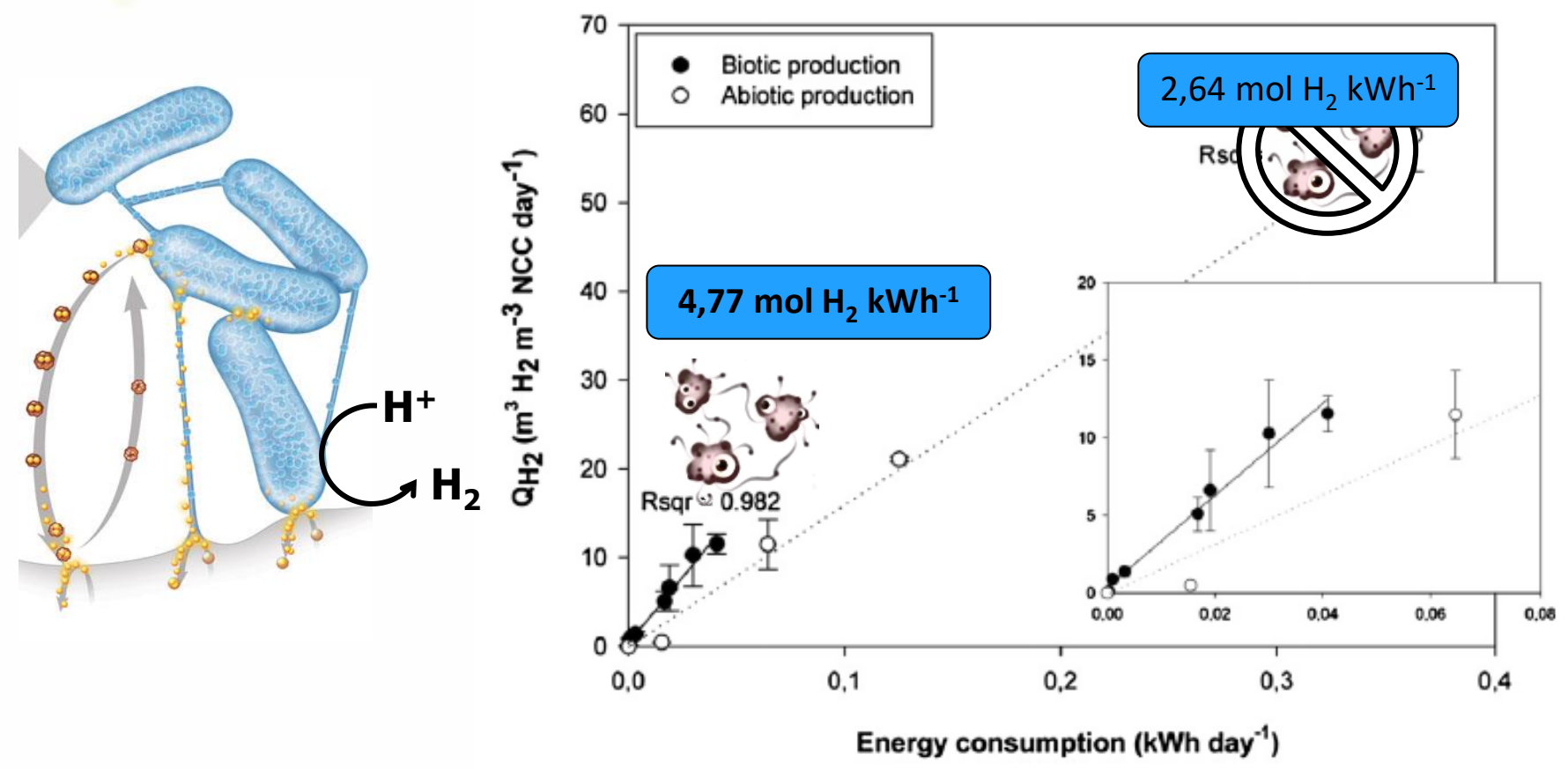
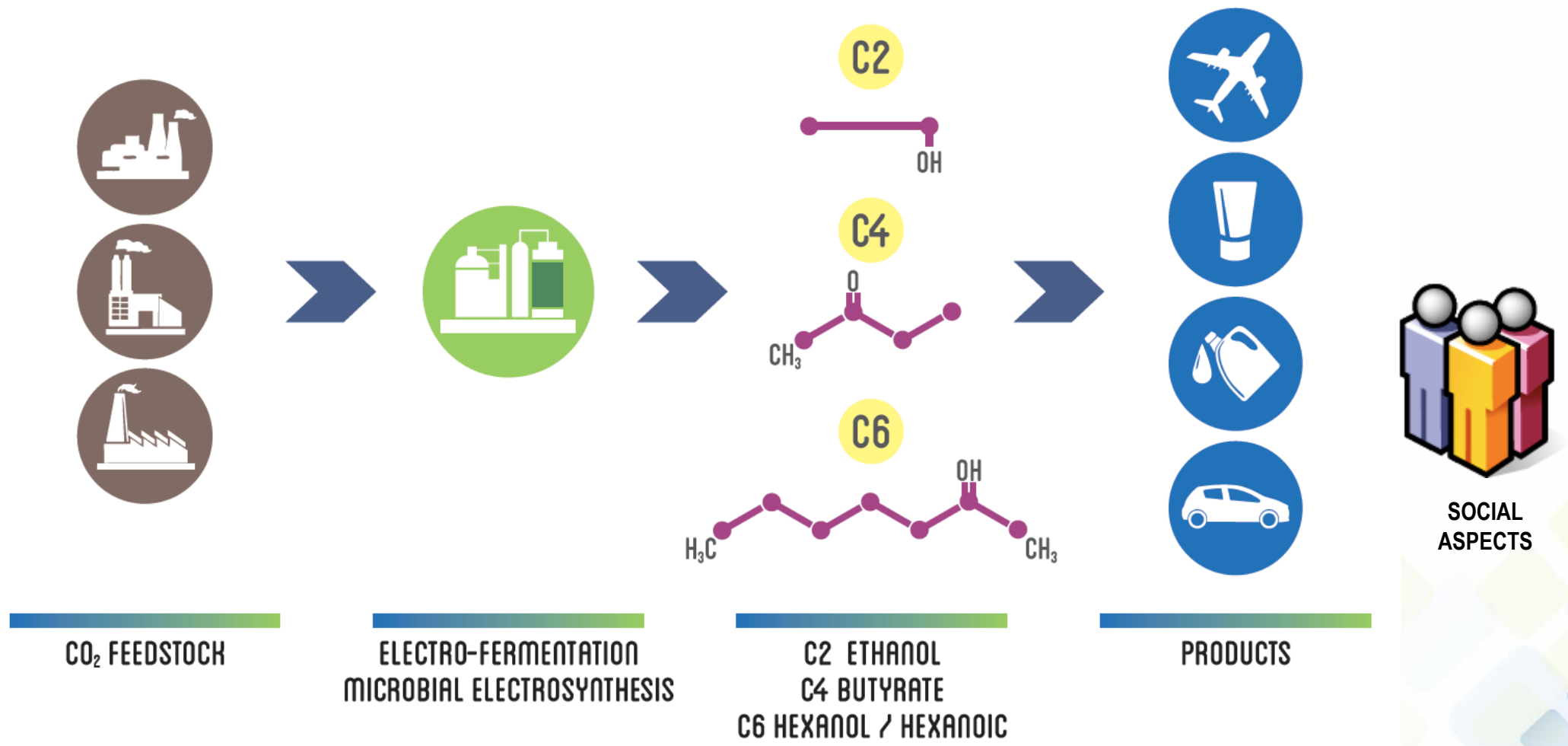
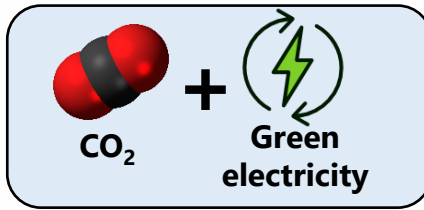

Fig. 2 – Hydrogen production rate versus energy consumed (linear regression fitted) in the biotic and abiotic MEC.

[Carbon recycling – Air recovery]



# [Carbon recycling – Air recovery]



**Hydrogen**

Assessment of biotic and abiotic graphite cathodes for hydrogen production in microbial electrolysis cells

Modelling the simultaneous production and separation of acetic acid from CO<sub>2</sub> using an anion exchange membrane microbial electrosynthesis system

Bioelectrochemical transformation of carbon dioxide to target compounds through microbial electrosynthesis

**Acetate**

**Butyrate**

Microbial Community Pathways for the Production of Volatile Fatty Acids From CO<sub>2</sub> and Electricity

Bio-electrorecycling of carbon dioxide into bioplastics.

**Bioplastics (PHA)**

**Microbial Protein**

**Butyrate**

Deciphering the electron transfer mechanisms for biogas upgrading to biomethane within a mixed culture biocathode

Microbial electrosynthesis of butyrate from carbon dioxide

Continuous acetate production through microbial electrosynthesis from CO<sub>2</sub> with microbial mixed culture

**Methane**

**Acetate**

Tracking H<sub>2</sub>-mediated microbial electrosynthesis of commodity chemicals from carbon dioxide

On the edge of research and technological application: a critical review on electromethanogenesis

Microbial electrosynthesis of butyrate from carbon dioxide: production and extraction

**Hydrogen**

**Methane**

**Butyrate**

Unravelling the factors that influence the bio-electrorecycling of carbon dioxide towards biofuels

**Ethanol**

## Thermodynamics analyses

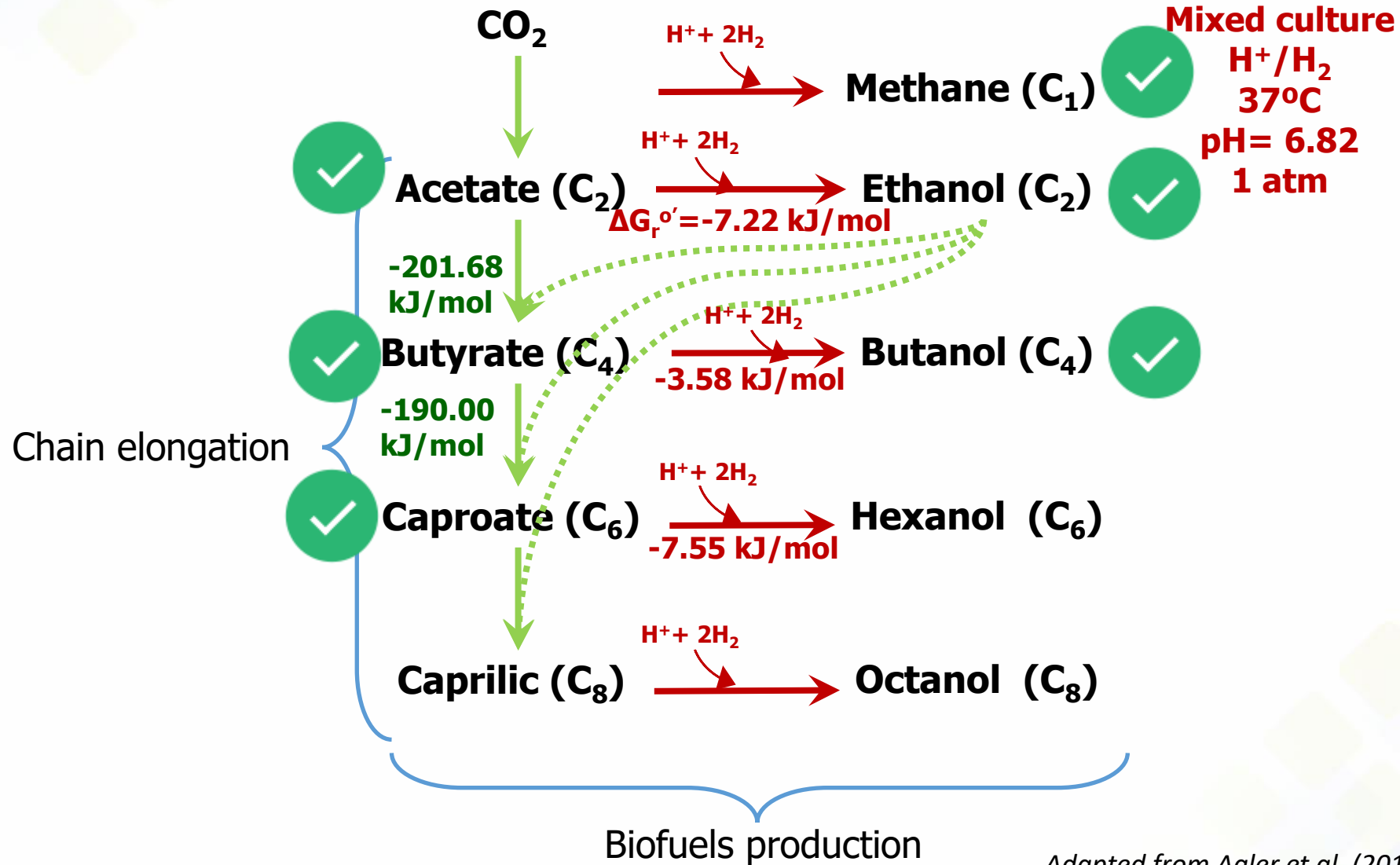

Adapted from Agler et al. (2011). Trends in Biotechnology

[Carbon recycling – Air recovery]

Simultaneous CH<sub>4</sub> and Cl<sub>2</sub> production

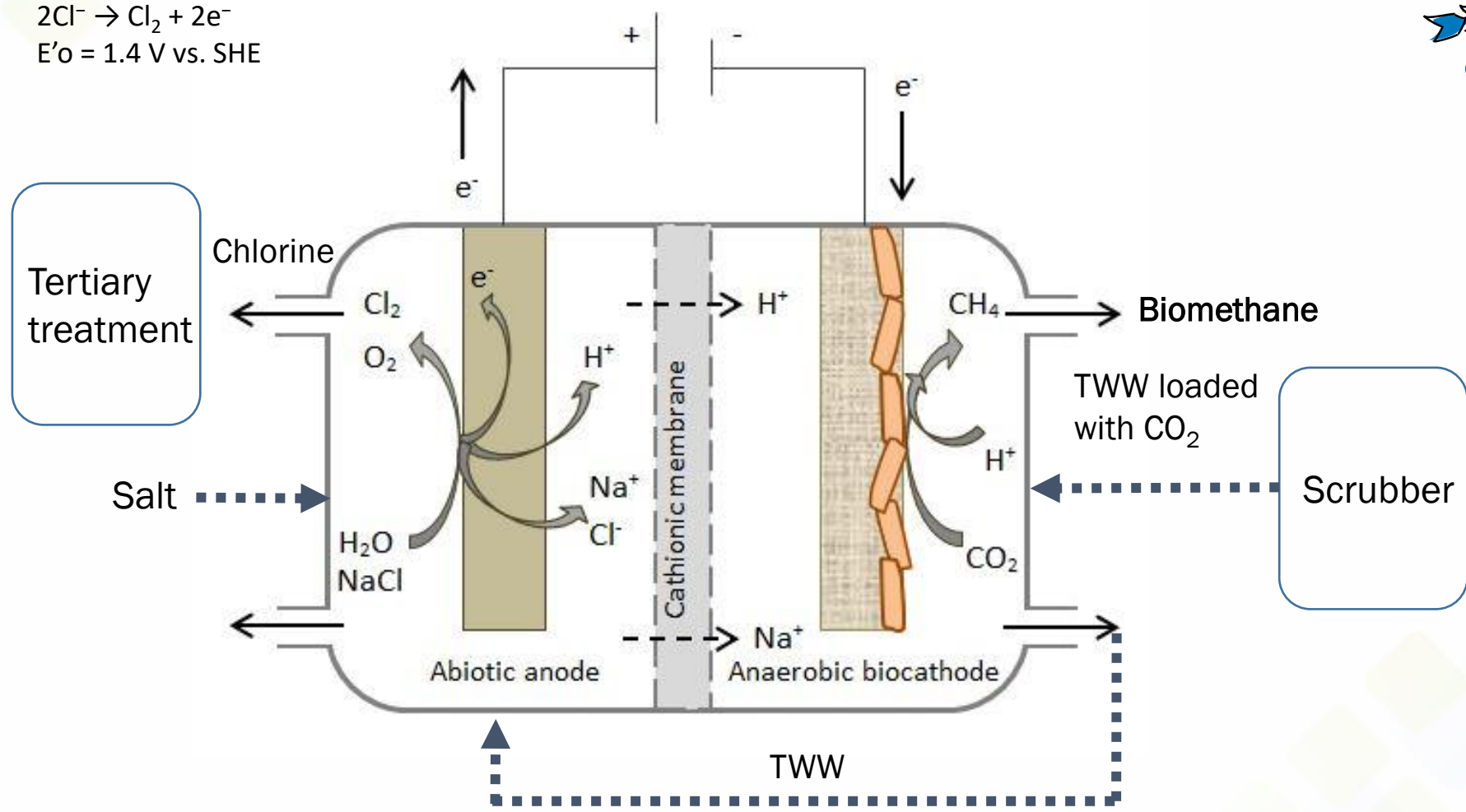
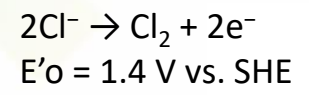

Batlle-Vilanova et al. (2019). *Science of The Total Environ.* 690, 352-360  
EP3527538A1. (2018)

# Case scenario

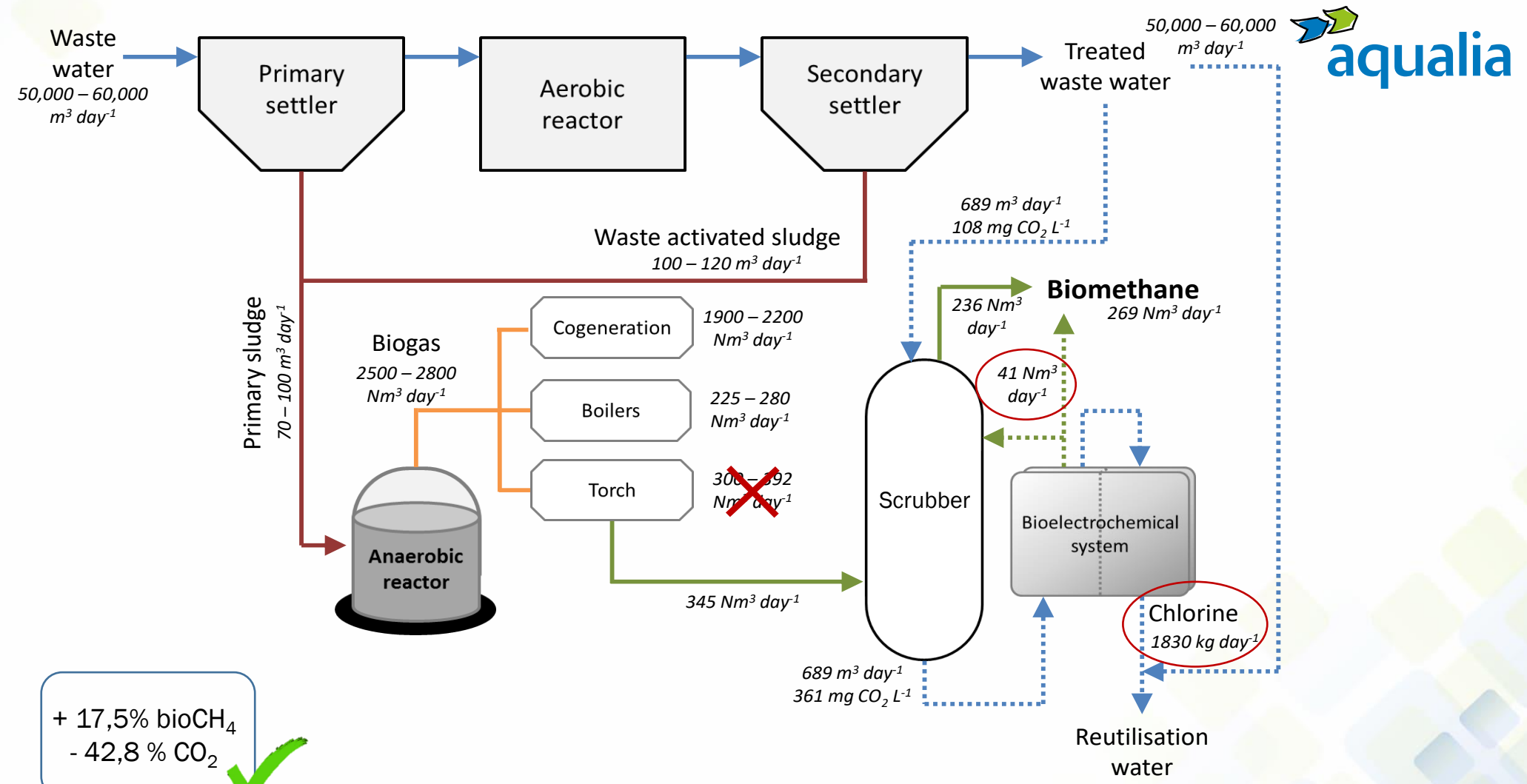

+ 17,5% bioCH<sub>4</sub>  
- 42,8 % CO<sub>2</sub>



## Advancing Anaerobic Digestion



### Improved Kinetics

Integrating bioelectrochemical systems directly into anaerobic digestion fundamentally accelerates the biological pathways. This synergy yields over a **40% increase in the specific methane production rate** compared to conventional methods.

### Enhanced Stability & Quality

The system consistently produces high-quality biogas (75-80%  $CH_4$ ) with significantly reduced  $H_2S$ . Additionally, the process demonstrates superior resilience against organic overloads and mitigates severe acid regression.

### Advancing Anaerobic Digestion



## Biogas production rate

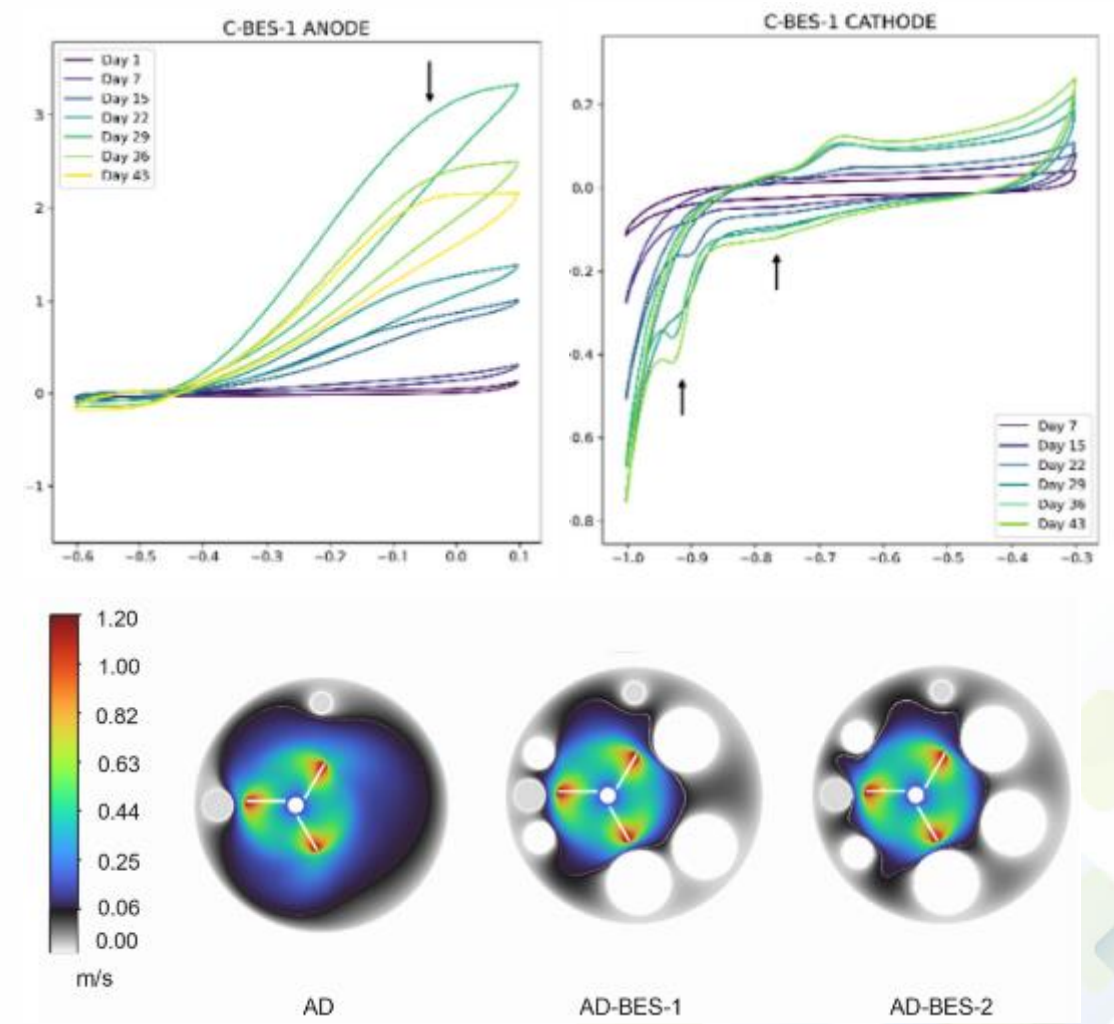
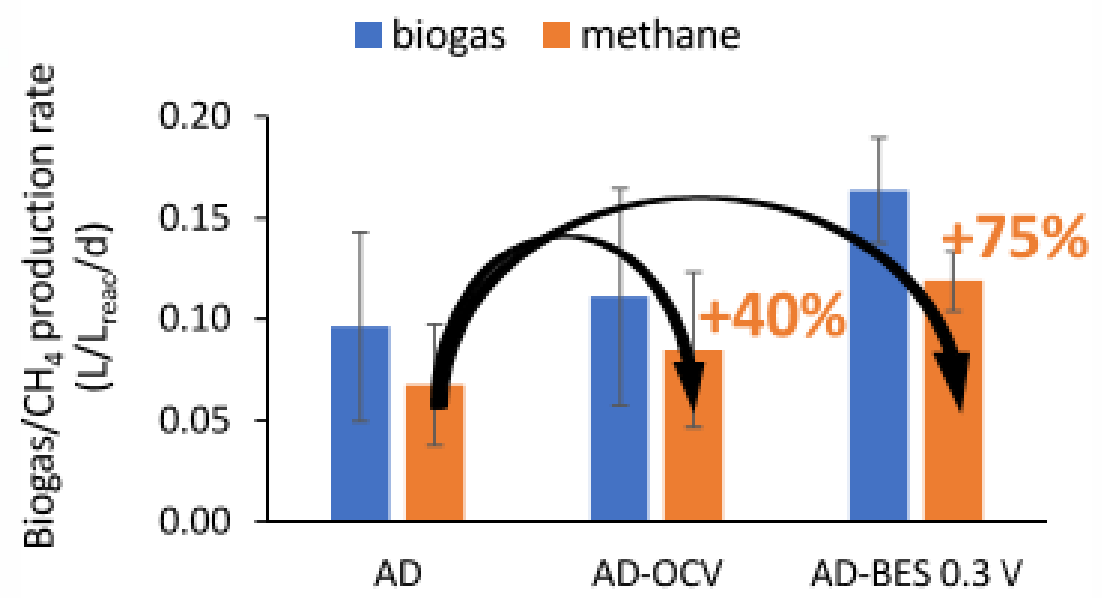

Molognoni D, Garcia M, Sánchez-Cueto P, Bosch-Jimenez P, Borràs E, Lladó S, et al. **Electrochemical optimization of bioelectrochemically improved anaerobic digestion for agricultural digestates' valorisation to biomethane.** Journal of Environmental Management 2025;373:123898.

S. Feilner, M. Espejo, M. Garcia, D. Molognoni, E. Borràs, K. Herkendell, **CFD simulation for optimizing flow dynamics in a bioelectrochemically enhanced single-chamber anaerobic digester.** International Journal of Thermofluids (2025) 101432.

[Carbon recycling – Air recovery]

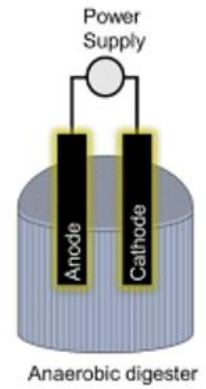

**LEITAT**  
managing technologies

In-situ BES  
Integration in AD



innovations in the  
**BIOMETHANE**  
uni**VERSE**

Relevant partners:



# ◆ [How does AD-BES work?]

- Promotion of VFAs oxidation reactions, H<sub>2</sub> production, and hydrogenotrophic methanogenesis
- Favoring Direct Interspecies Electron Transfer (DIET)
- Electro-Fermentation process, with improved hydrolytic and acidogenic phases due to better redox balance
- Leitat validated AD-BES from lab to pilot scale (TRL 7)

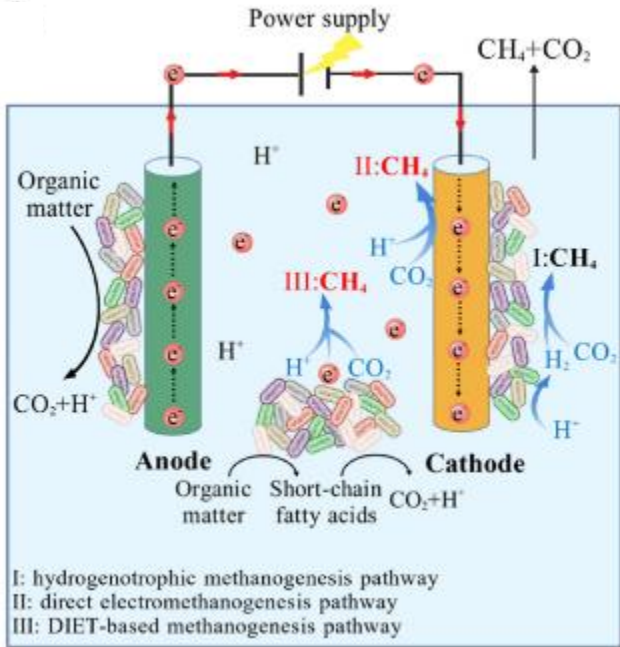
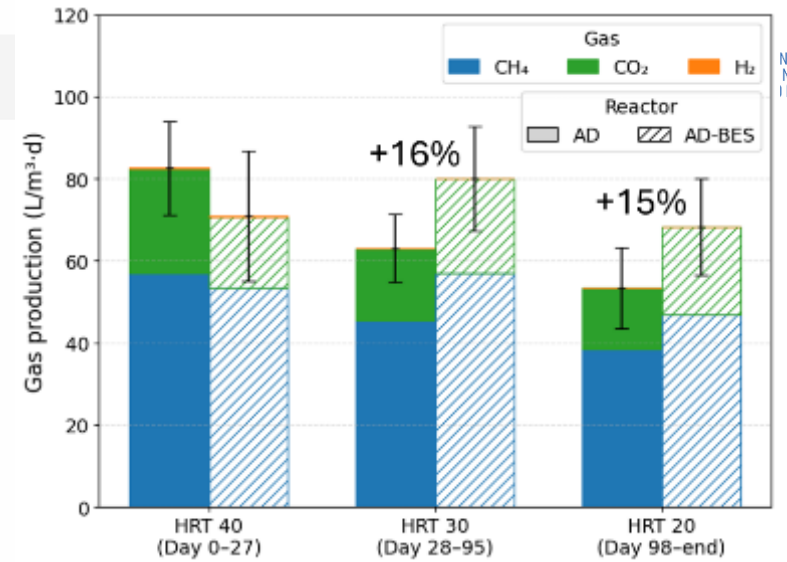

innovations in the  
**BIOMETHANE**  
uni**VERSE**



- HRT  
40 → 30 → 20 days
- +25% CH<sub>4</sub> at HRT 30
- Stable microbial community for AD-BES

<sup>1</sup>S. Tan, L. Li, S. Liu, L. Han, C. Duan, Y. Liu, X. Wang, **Biogas upgrading via microbial electrolysis cell-integrated anaerobic digestion: A critical review of stabilization strategies towards practical application**, *Journal of Environmental Management* 2026.

<sup>2</sup>Garcia-Montolio M. et al. **Bioelectrochemical stimulation enhances methane production and microbial stability in anaerobic digestion**. *Bioelectrochemistry*, under review

[Carbon recycling – Air recovery]

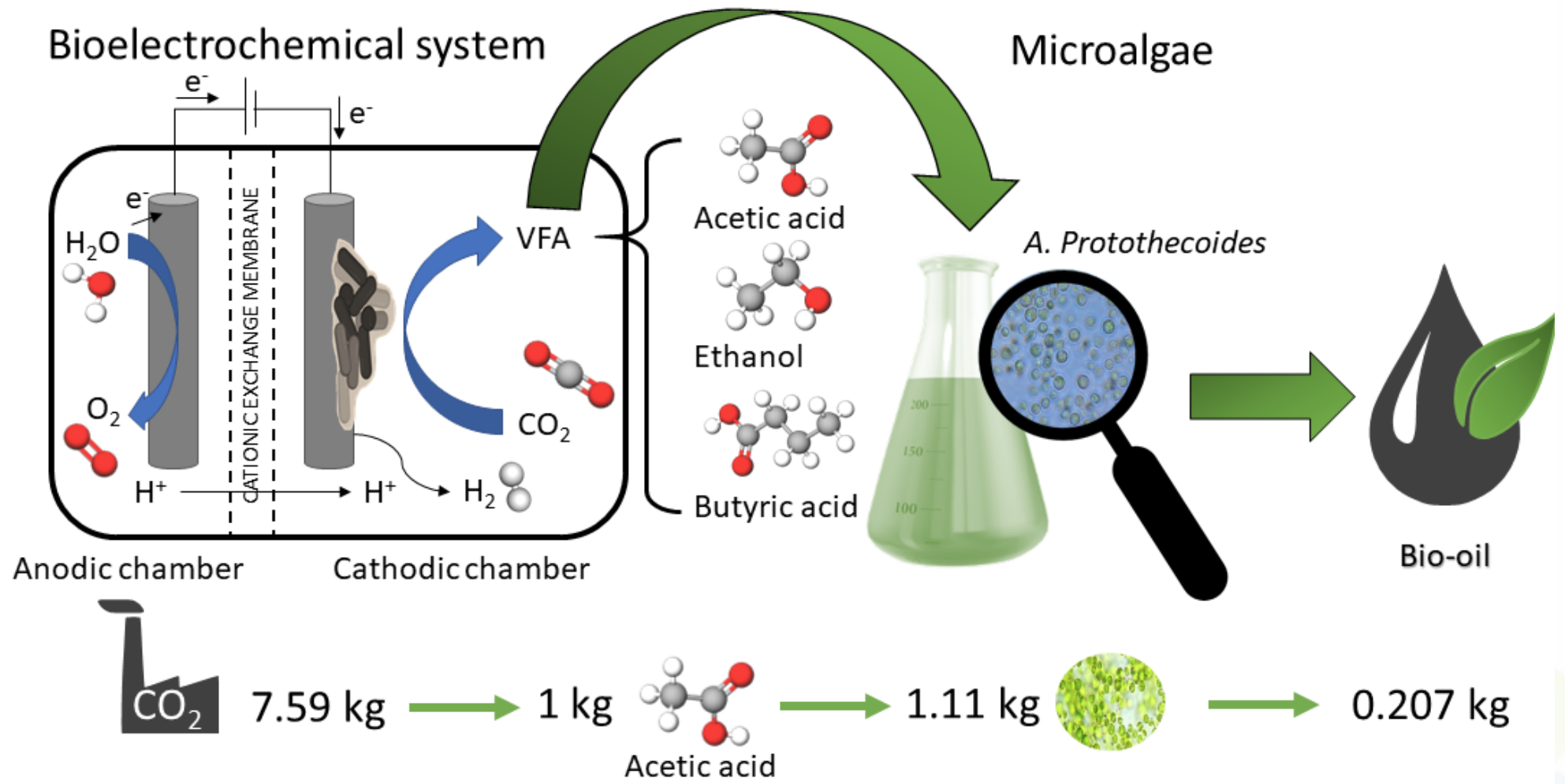

Bolognesi et al., 2022. Carbon dioxide to bio-oil in a bioelectrochemical system-assisted microalgae biorefinery process. Sustainable Energy & Fuels 6(1), 150-161. <https://doi.org/10.1039/D1SE01701B>

[Carbon recycling – Air recovery]



UNIVERSITÀ DEGLI STUDI DI MILANO

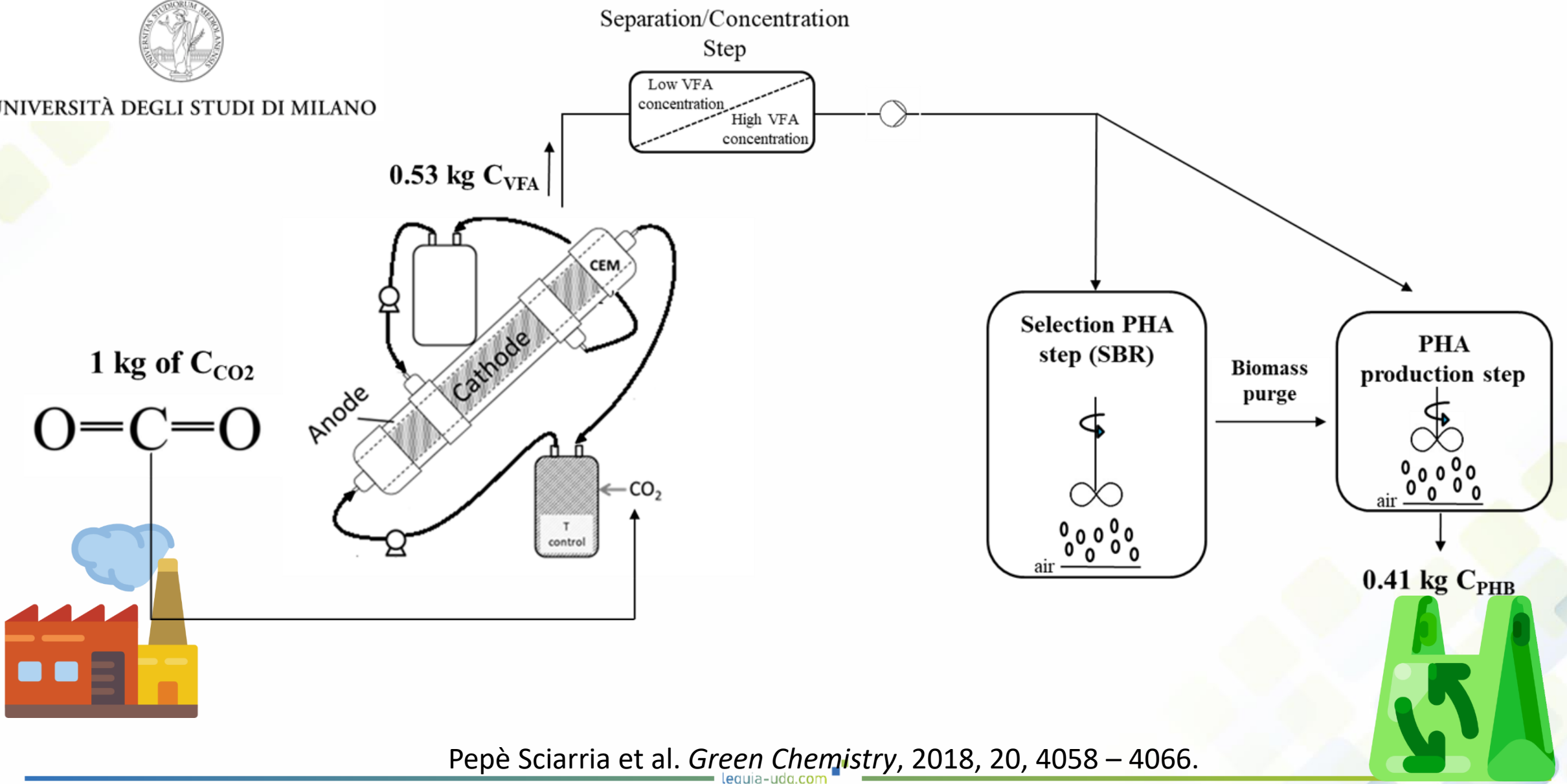

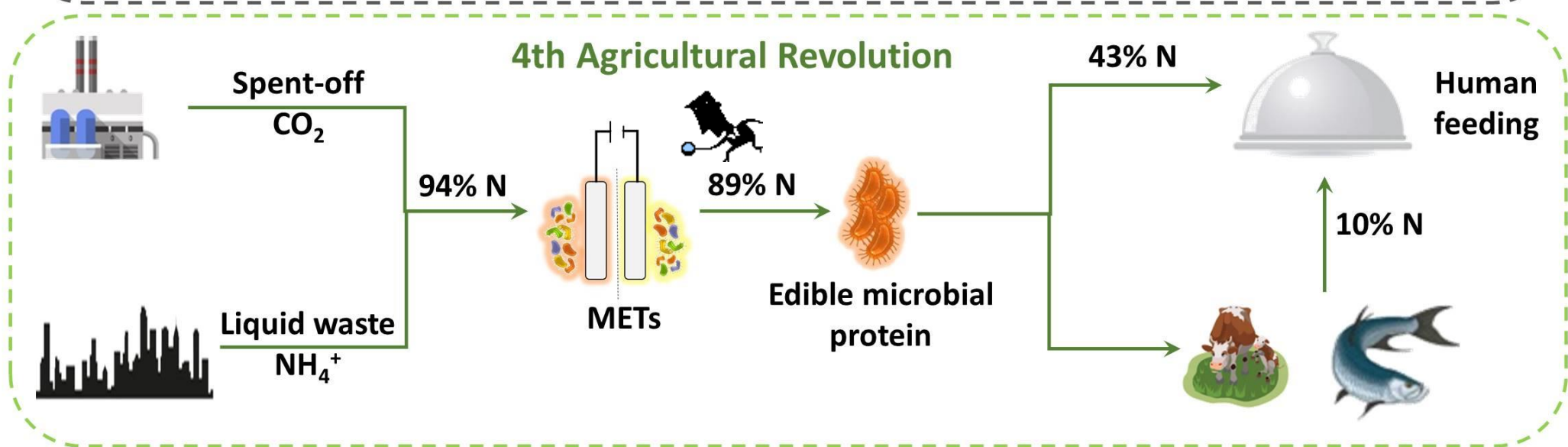
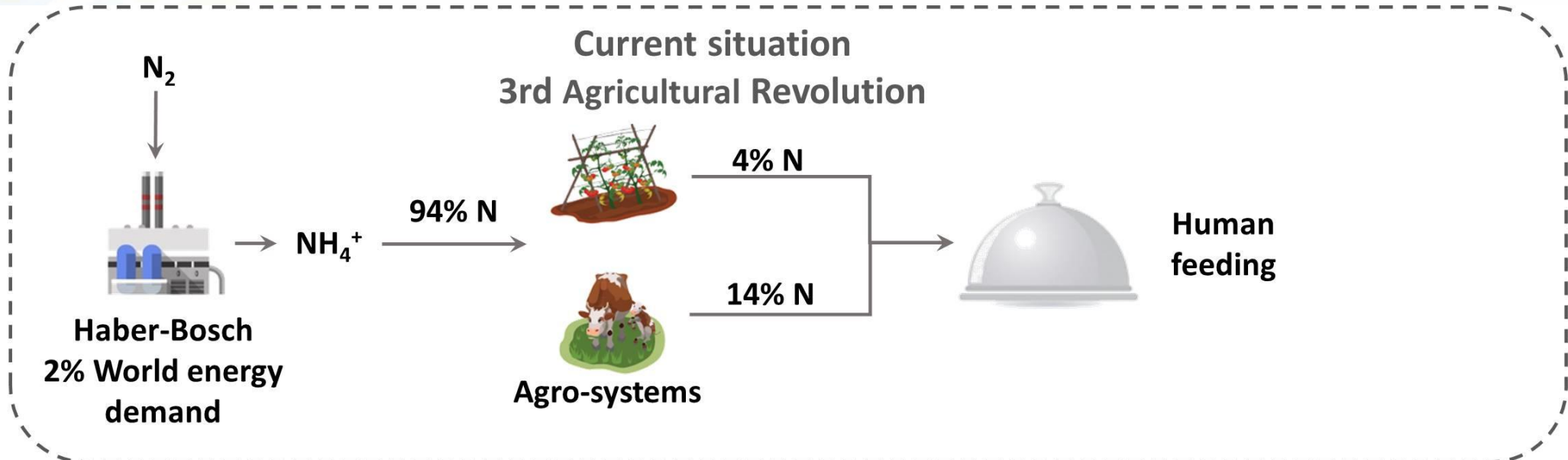

Hydrogen-oxidizing bacteria (HOB)

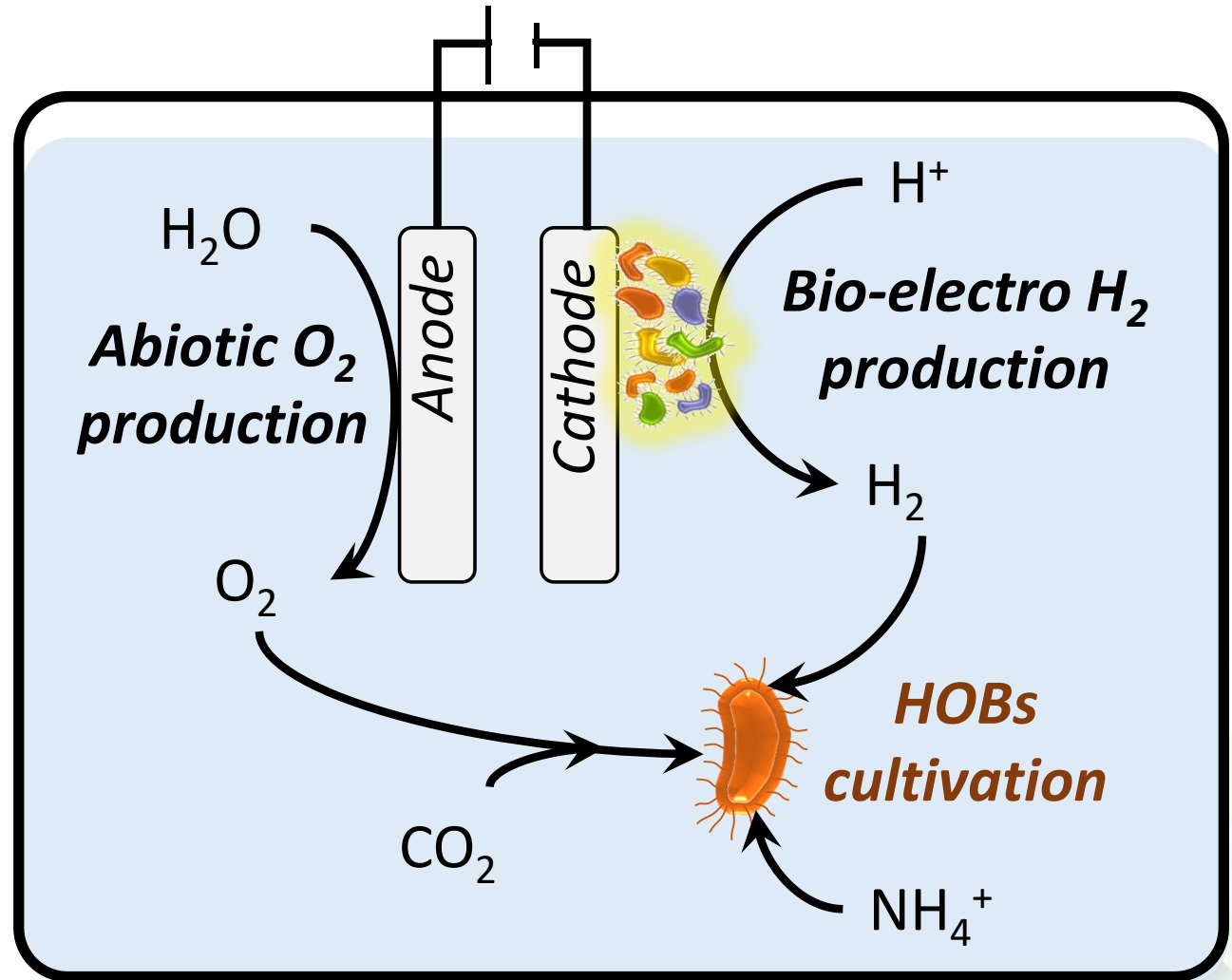
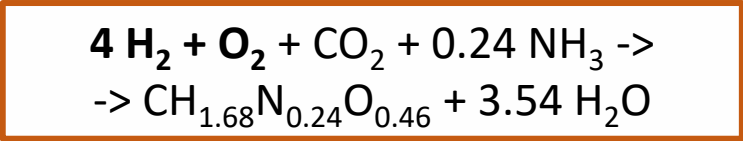
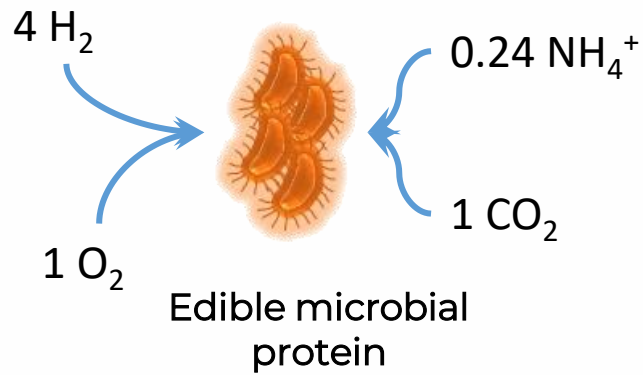

Pous et al., 2022. Bioresource Technology Reports 18, 101010

[Power-to-Protein: Our approach]

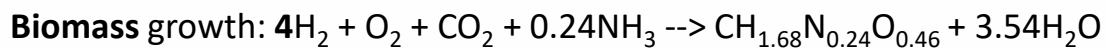
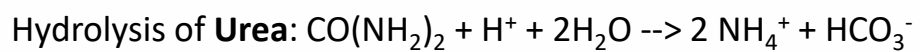
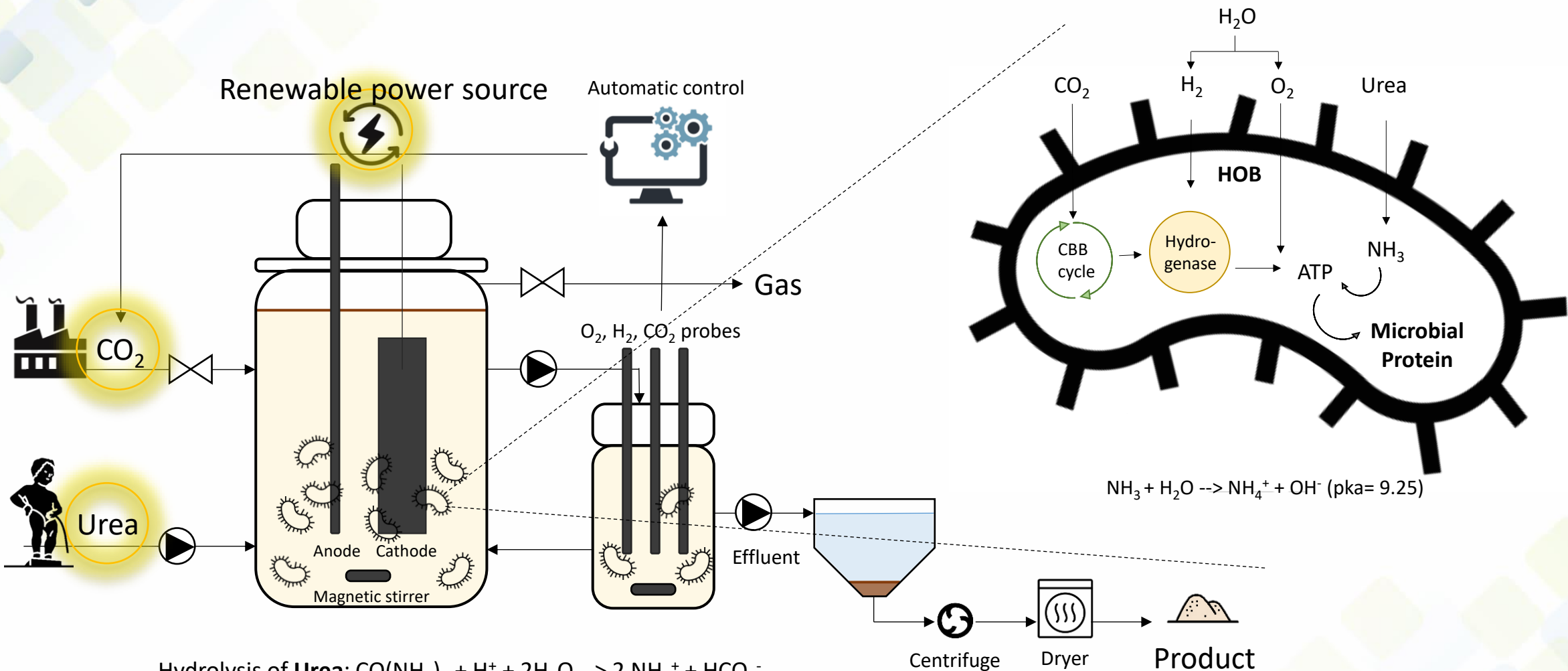

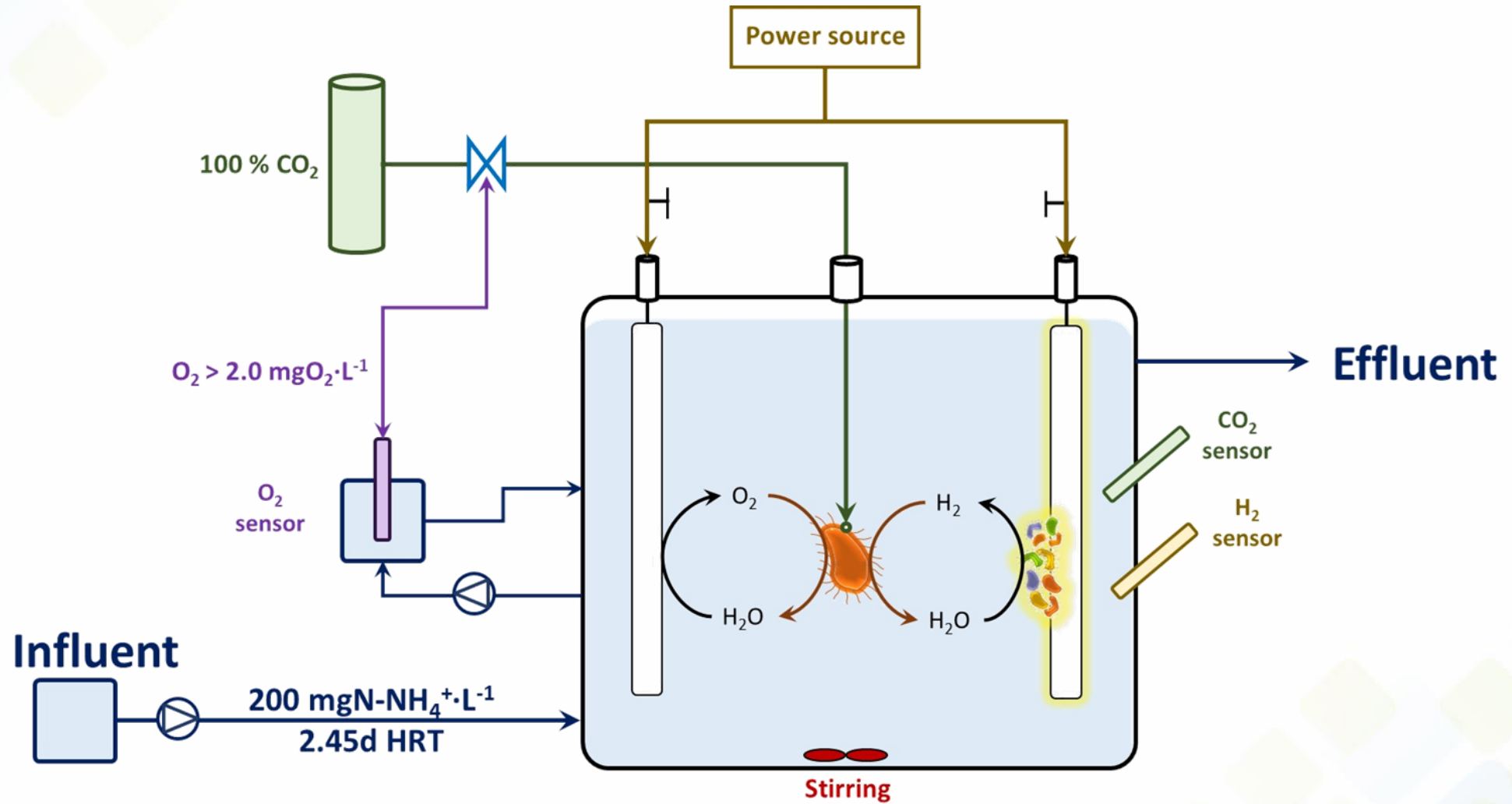

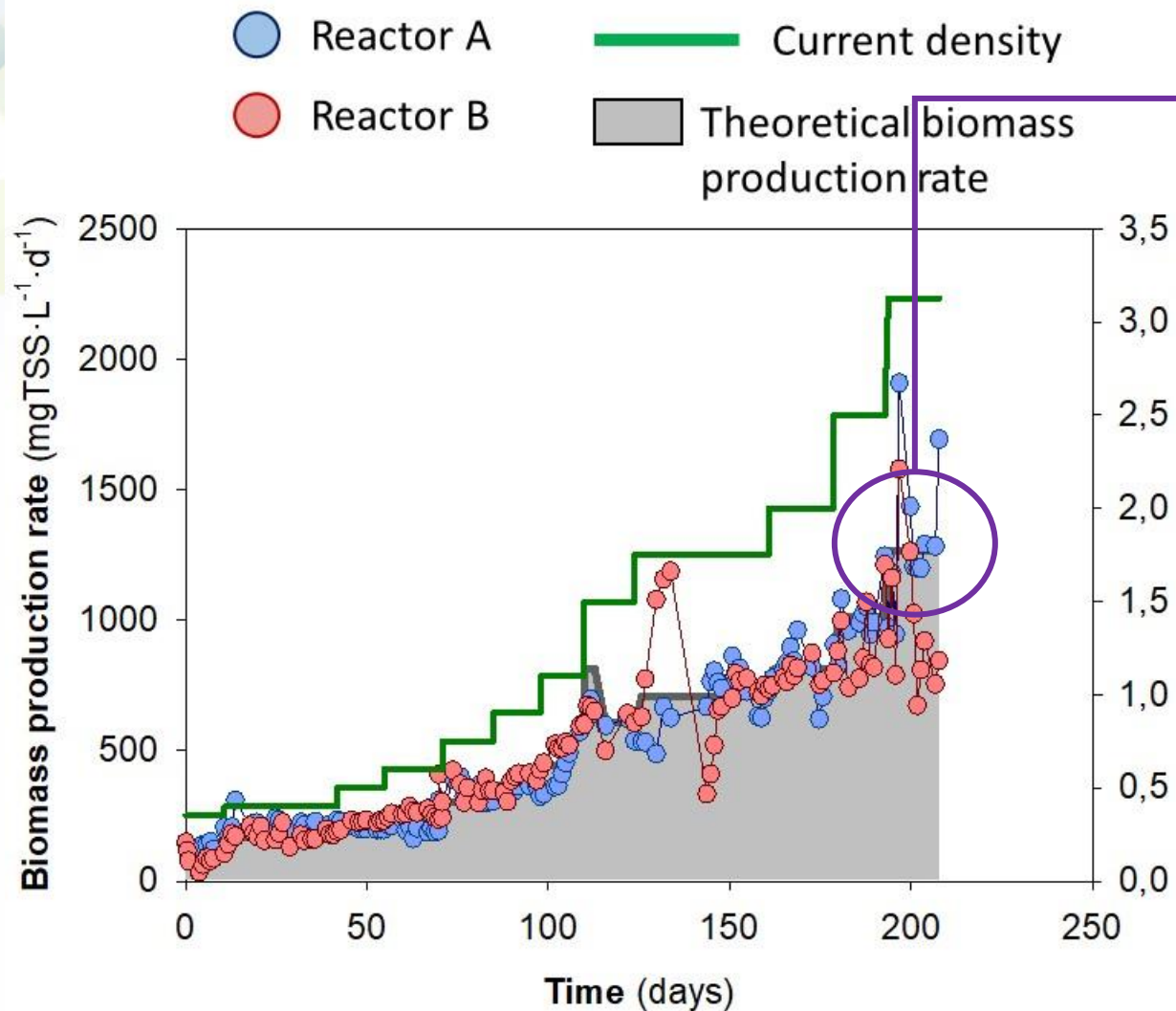

Production rate	1236 ± 47 mgTSS·L <sup>-1</sup> ·d <sup>-1</sup>
-----------------	--



Protein content  
60 – 70 %

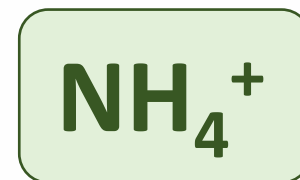

N-NH <sub>4</sub> <sup>+</sup> consumption rate	62 ± 5 mgN·L <sup>-1</sup> ·d <sup>-1</sup>
--	---

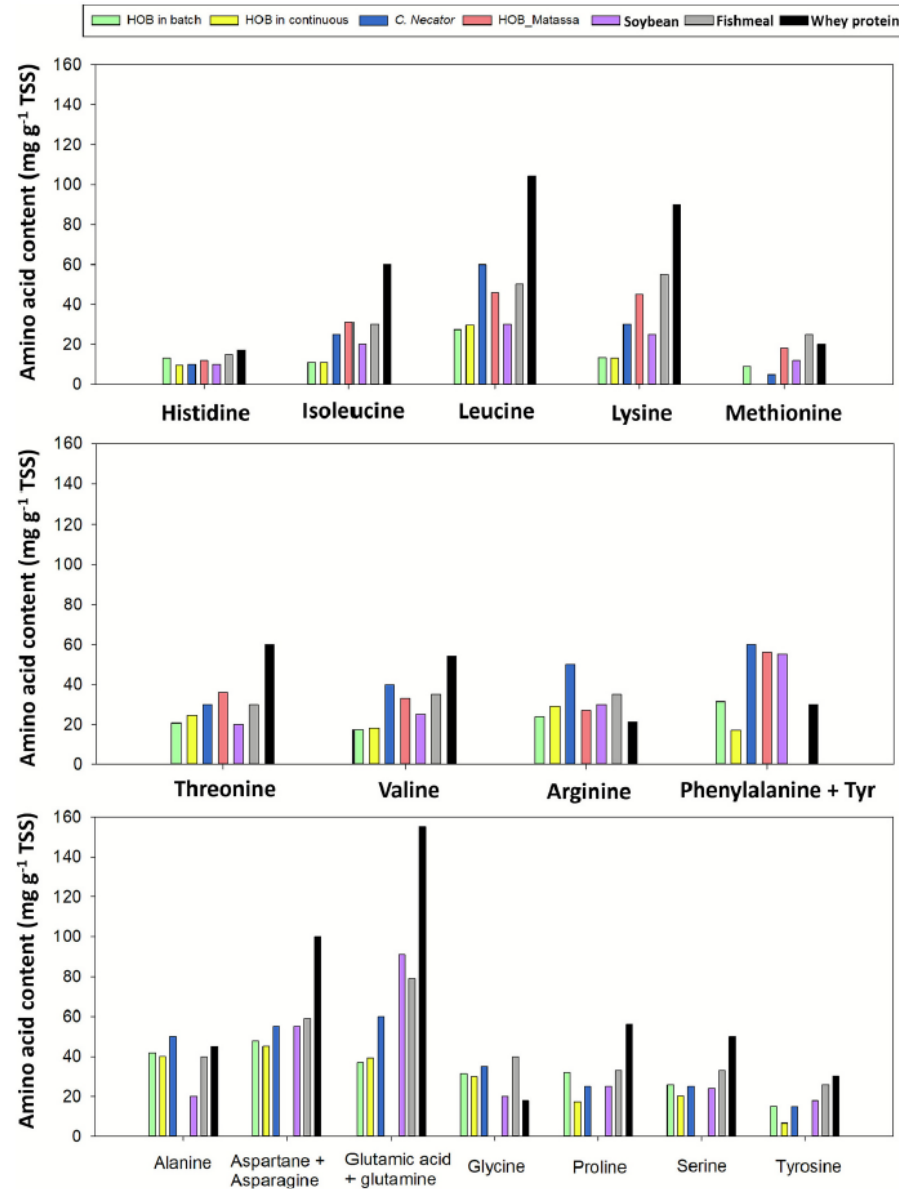

**Composition of freeze-dried microbial biomass**

Protein (%)	65.17 ± 0.55
Fat (%)	7.20 ± 0.77
Carbohydrate (%)	13.58 <sup>a</sup>
Moisture (%)	2.16 ± 0.23
Ash (%)	11.89 ± 0.06

<sup>a</sup> estimation by difference

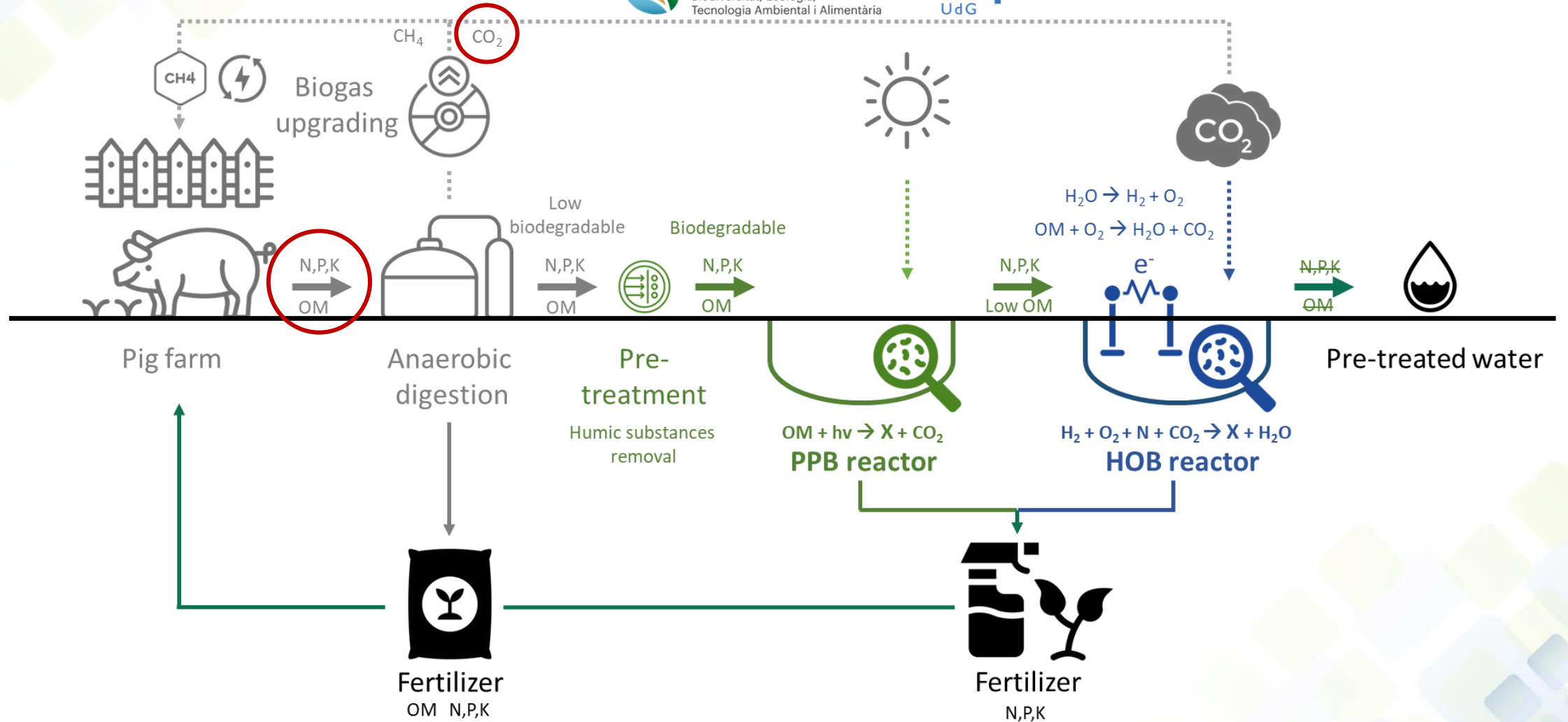

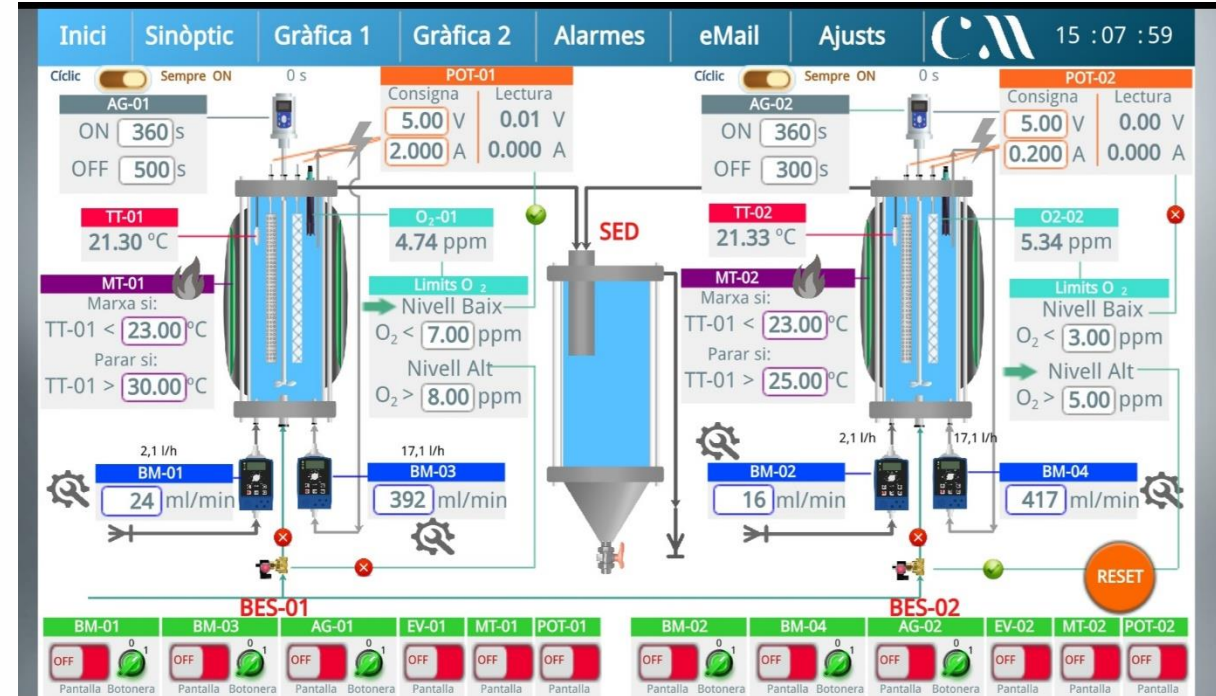

TRL  
3

TRL  
4

TRL  
5





- ✓ **Resource recovery** would become a new niche for the MET platform
- ✓ Zero-chemical-input technology
- ✓ Minimization of intermediates
- ✓ Lab-to-pilot scaling achieved



- Move towards upscaling METs
- Move from synthetic to real water streams
- Keep in mind the counter electrode
- Pathway for regulatory approval of microbial proteins

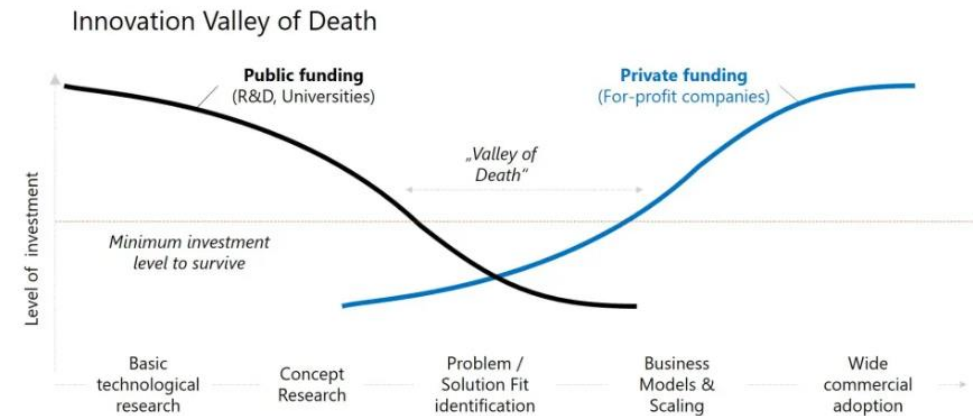

# Processos bioelectroquímics

**Sebastià Puig**

[sebastia.puig@udg.edu](mailto:sebastia.puig@udg.edu)

X @sebastia.puig

in sebastia-puig



## Acknowledgements (selected):