



UNIVERSITAT POLITÈCNICA
DE CATALUNYA
BARCELONATECH



CITCEA UPC
Boosting the future of energy



TECHNOLOGY CENTER
UNIVERSITAT POLITÈCNICA
DE CATALUNYA
BARCELONATECH



Introducció tècnica a l'HVDC

20 d'abril 2026, Barcelona

Jaume Girona Badia
Jaume.girona@upc.edu

Marc Cheah Mañe, Max Tavana, Eduardo Prieto-Araujo and Oriol Gomis-Bellmunt



Funded by
the European Union



Engineers
Industrials de Catalunya

Introducció

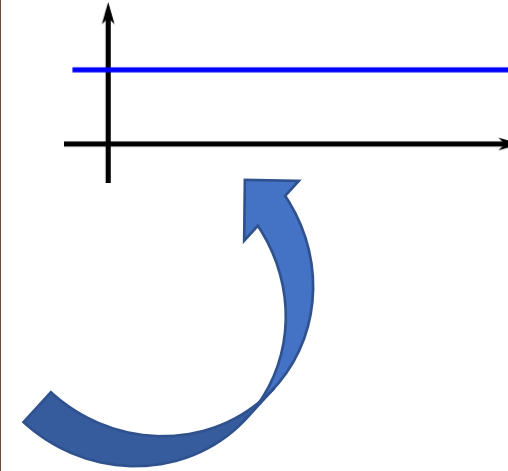
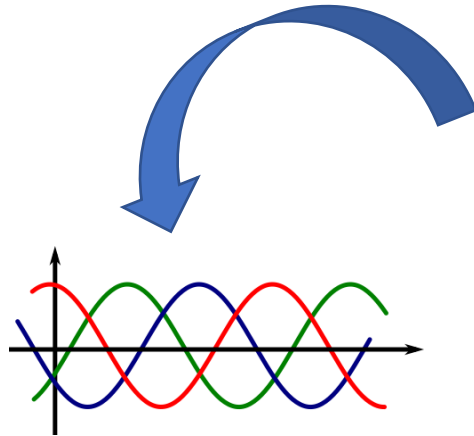

Font: Thinkgeek

- Orígens de l'electricitat 1885-1890s:
 - Thomas Edison
 - Nikola Tesla (i George Westinghouse)
- Guerra dels corrents (AC vs. DC)
 - Avantatges de l'AC (corrent altern):
 - Fàcil d'augmentar el voltatge (transformadors)
 - Interrompre els corrents DC (corrent continu) era difícil

Introducció

Els sistemes HVDC s'utilitzen actualment per transportar grans quantitats de potència elèctrica, sobretot quan cal:

- Interconnectar sistemes asíncrons,
- Establir connexions que requereixen cables llargs o línies aèries molt llargues.

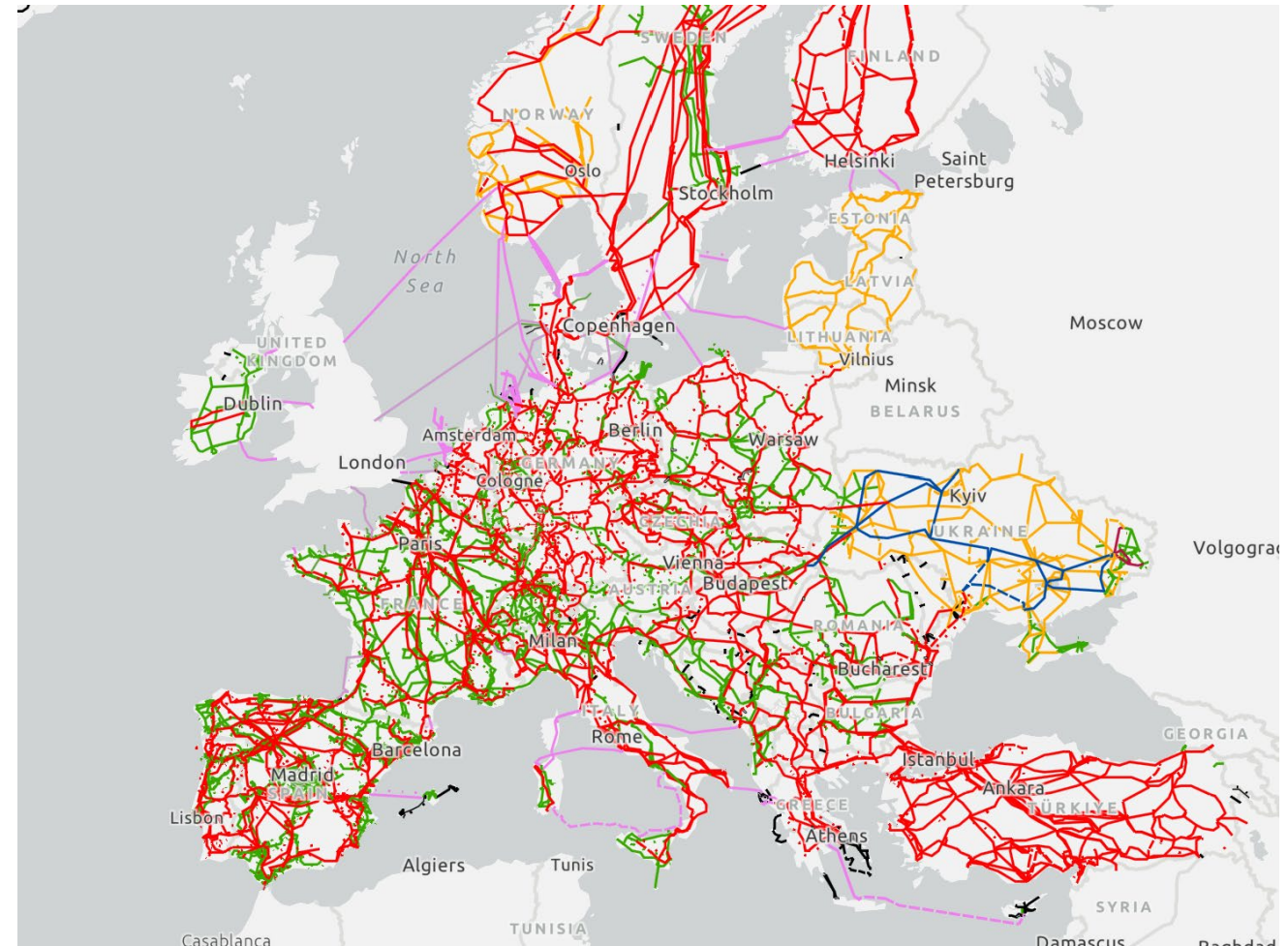

Introducció

Xarxa local del parc eòlic

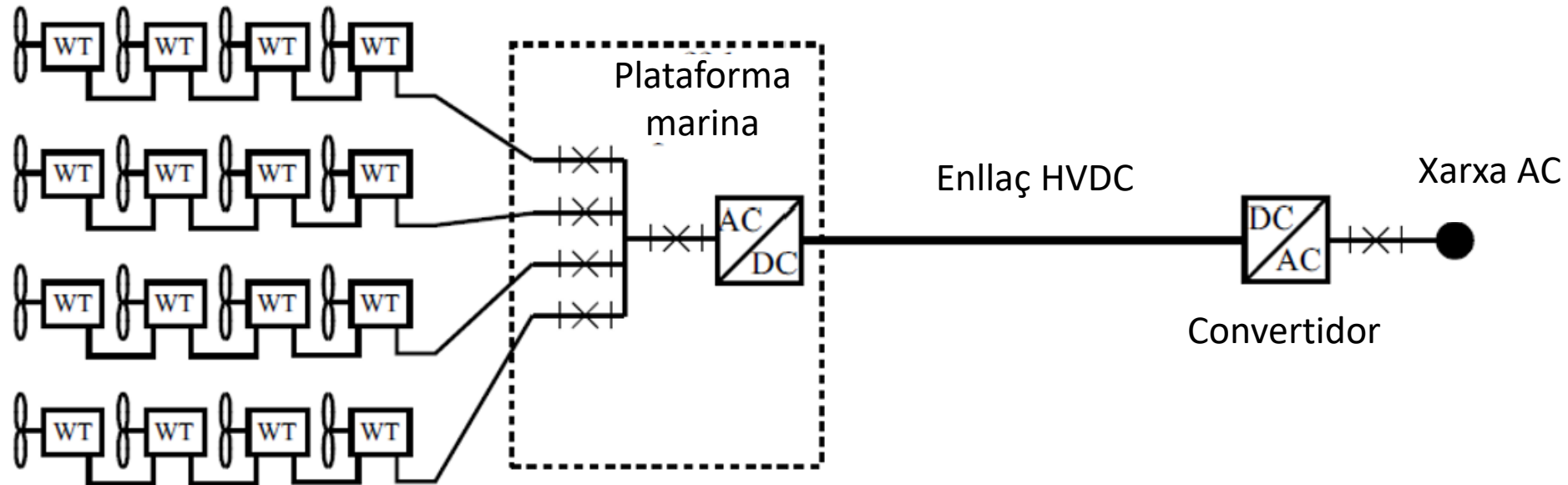

Font: Stefan Lundberg

Introducció

L'electrònica de potència ha evolucionat molt des d'aquell període.

- **1954 Gotland (20 MW, 200 A, 100 kV) LCC, ABB, vàlvules d'arc de mercuri.**
- Vàlvules de tiristors / Estació convertidora **d'Eel River 1972 (320 MW) LCC GE, Tiristor.**
- Convertidors de font de tensió (VSC) / HVDC Hellsjön–Grängesberg, **1997 ABB, IGBT.**
- Convertidor VSC-MMC / **Trans Bay Cable** de San Francisco el **2010 Siemens, IGBT.**

Convertidors - LCC

LCC (Line-Commutated Converters)

- Es basa en **tiristors**, que són dispositius que es poden tancar però no obrir a voluntat
- Requereixen una xarxa AC forta
- Molt alta eficiència i capacitat de potència
- **Inconvenients:**
 - Consumeixen molta potència reactiva
 - Generen molts harmònics
 - Necessiten bancs de filtres

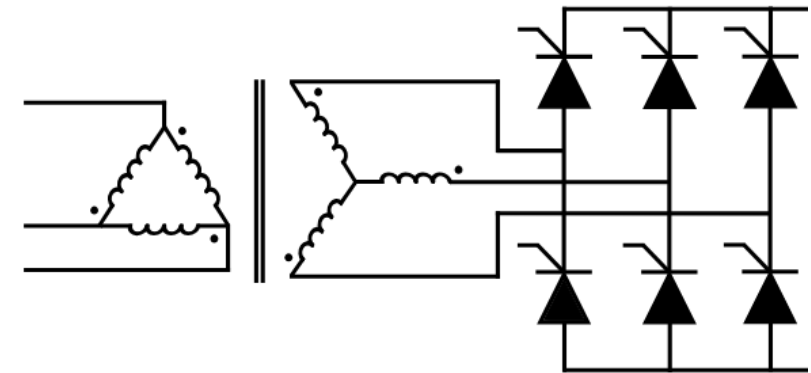

Font: Max Tavana

Convertidors – LCC

Operació

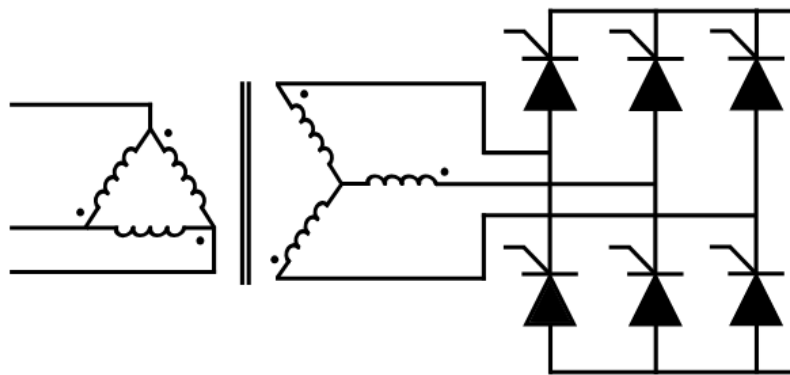

Font: Max Tavana

Currents in each valve

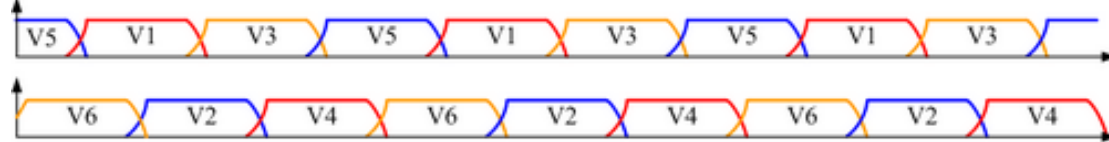

DC voltage, line to neutral

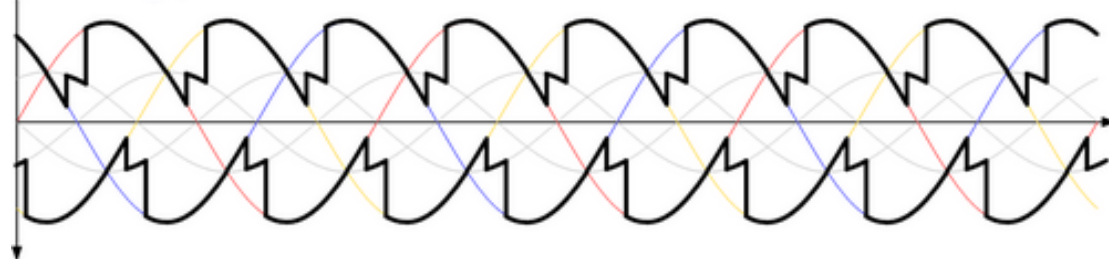

DC voltage, line to line

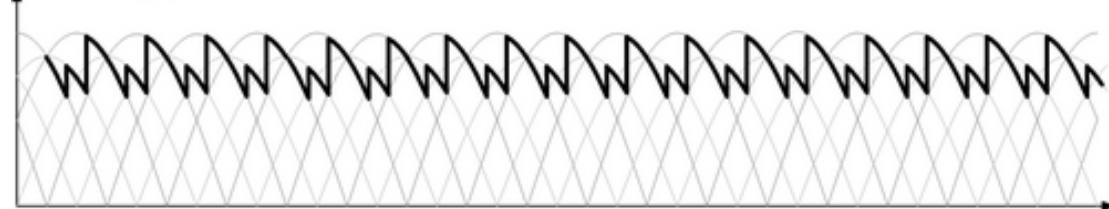

Font: Wikipedia

Convertidors - VSC

VSC (Voltage Source Converters)

- Poden controlar de forma independent la potència activa i la reactiva
- Poden arrencar una xarxa des de zero (Black Start)
- No necessiten una xarxa d'AC externa per commutar (poden connectar-se a xarxes "febles" o parcs eòlics offshore)
- Harmònics d'alta freqüència

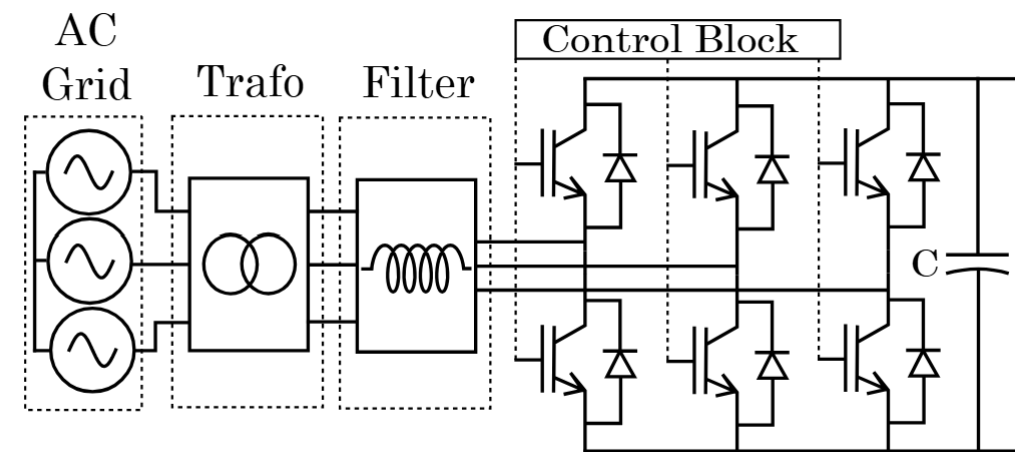

Font: Max Tavana

Convertidors - VSC

Operació

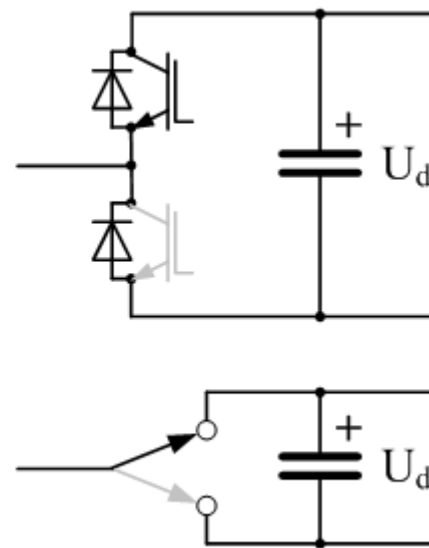
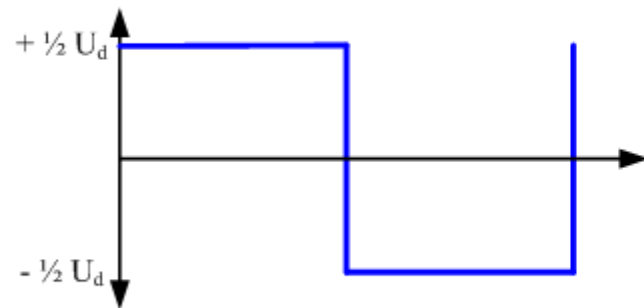

Font: Wikipedia

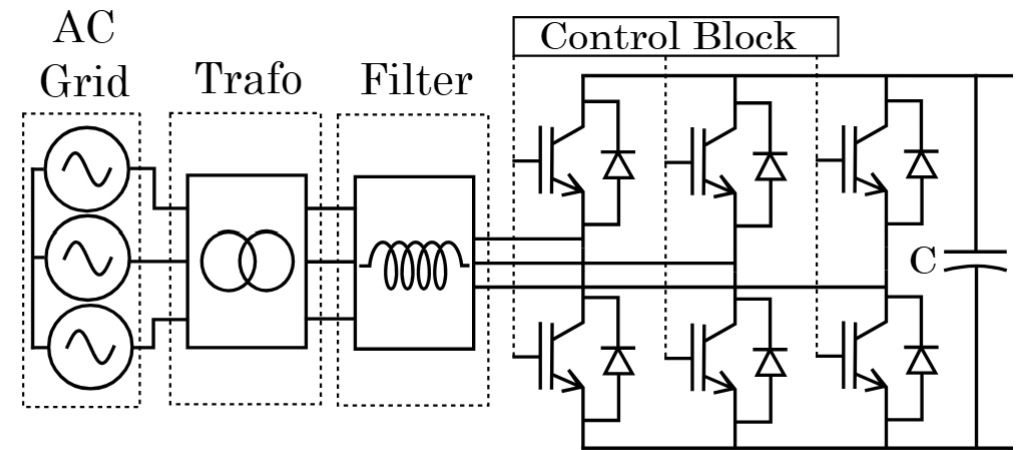

Font: Max Tavana

Convertidors - VSC - MMC

VSC (Voltage Source Converters)

MMC (Modular Multilevel Converter)

- Poden controlar de forma independent la potència activa i la reactiva
- Poden arrencar una xarxa des de zero (Black Start)
- No necessiten una xarxa d'AC externa per commutar (poden connectar-se a xarxes "febles" o parcs eòlics offshore)
- **Pràcticament no té harmònics**

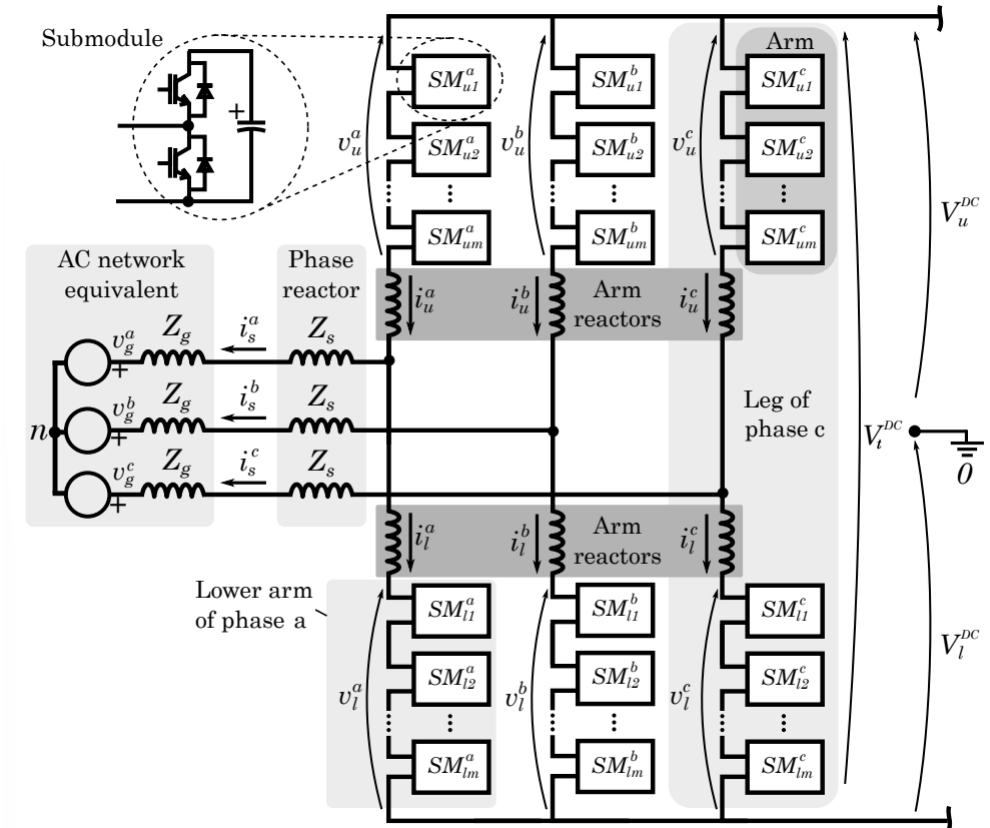

Font: Tesis Eduardo Prieto Araujo

Convertidors - VSC - MMC

Operació

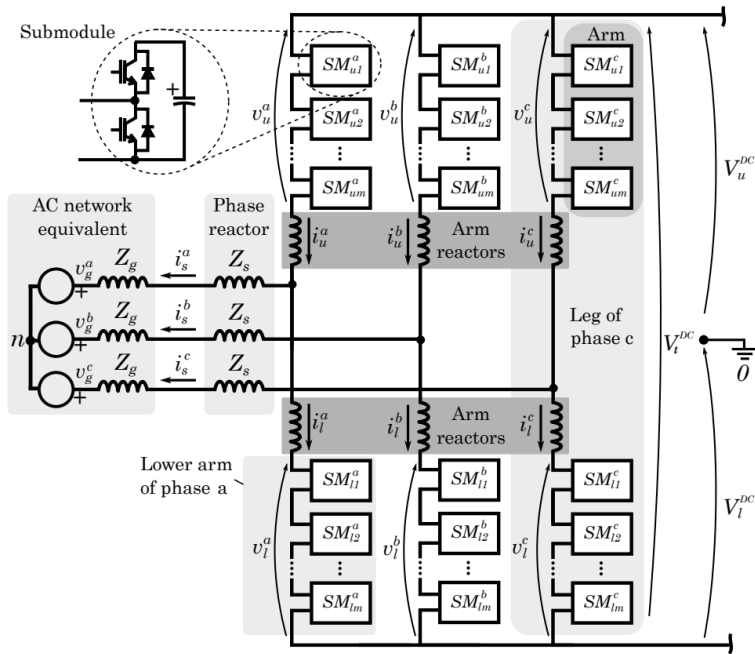

Font: Tesis Eduardo Prieto Araujo

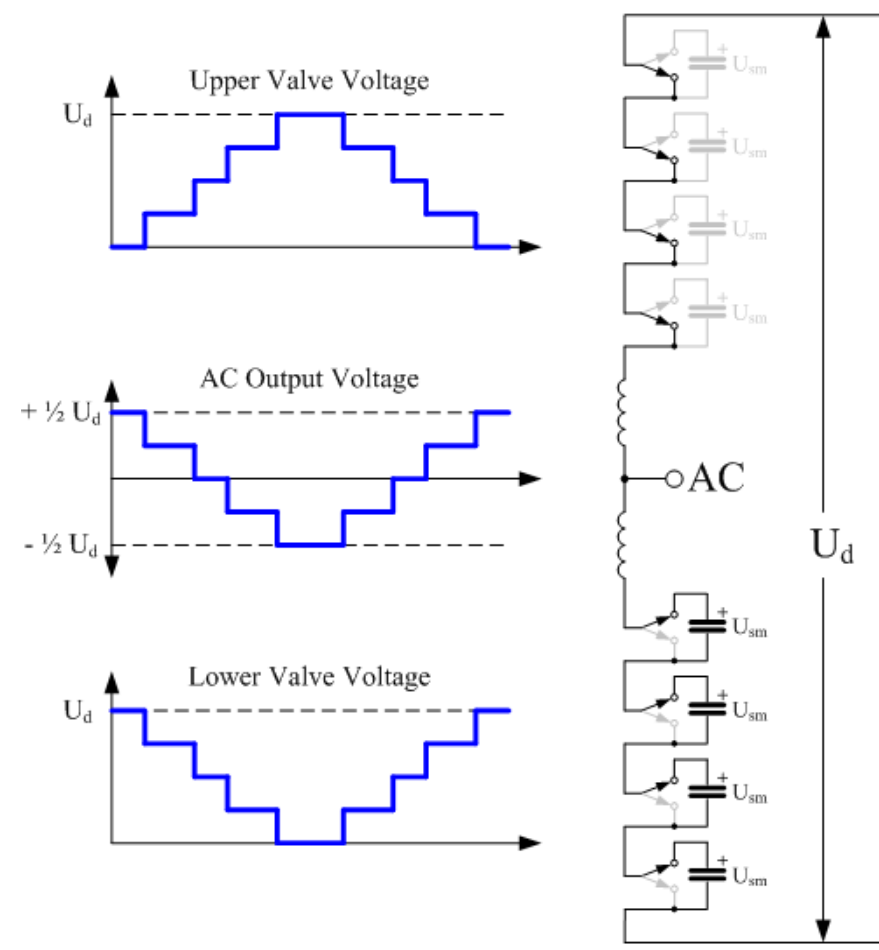

Font: Wikipedia

Possibles connexions

Enllaç asimètric monopolar

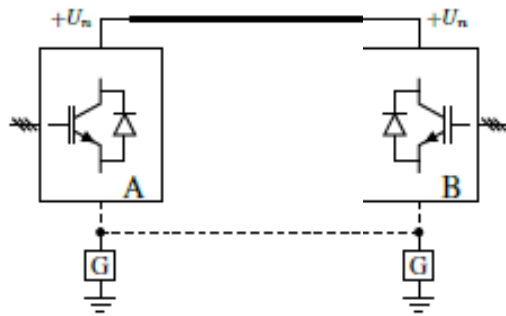

Enllaç simètric monopolar



Enllaç bipolar

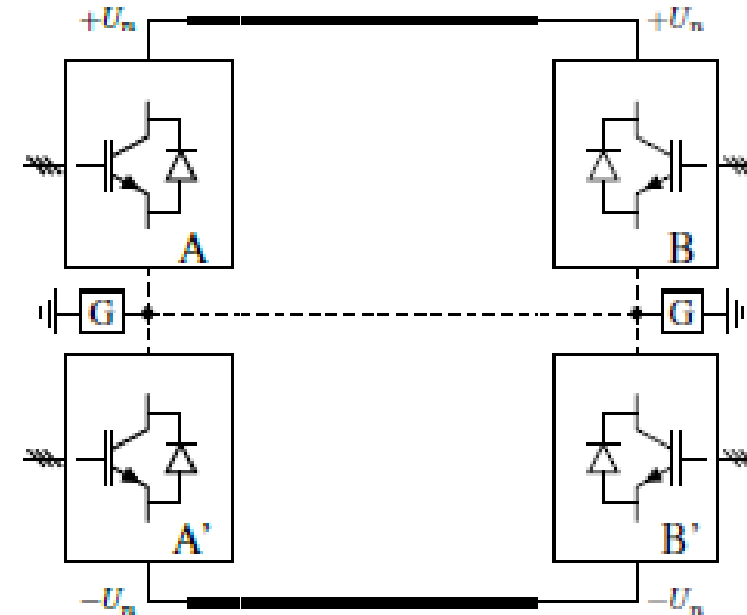

Font: HVDC GRIDS for offshore and supergrid of the future.

Inte

Project

- 2011
Santa
244 k
- 2015
Baixa
64,5 l

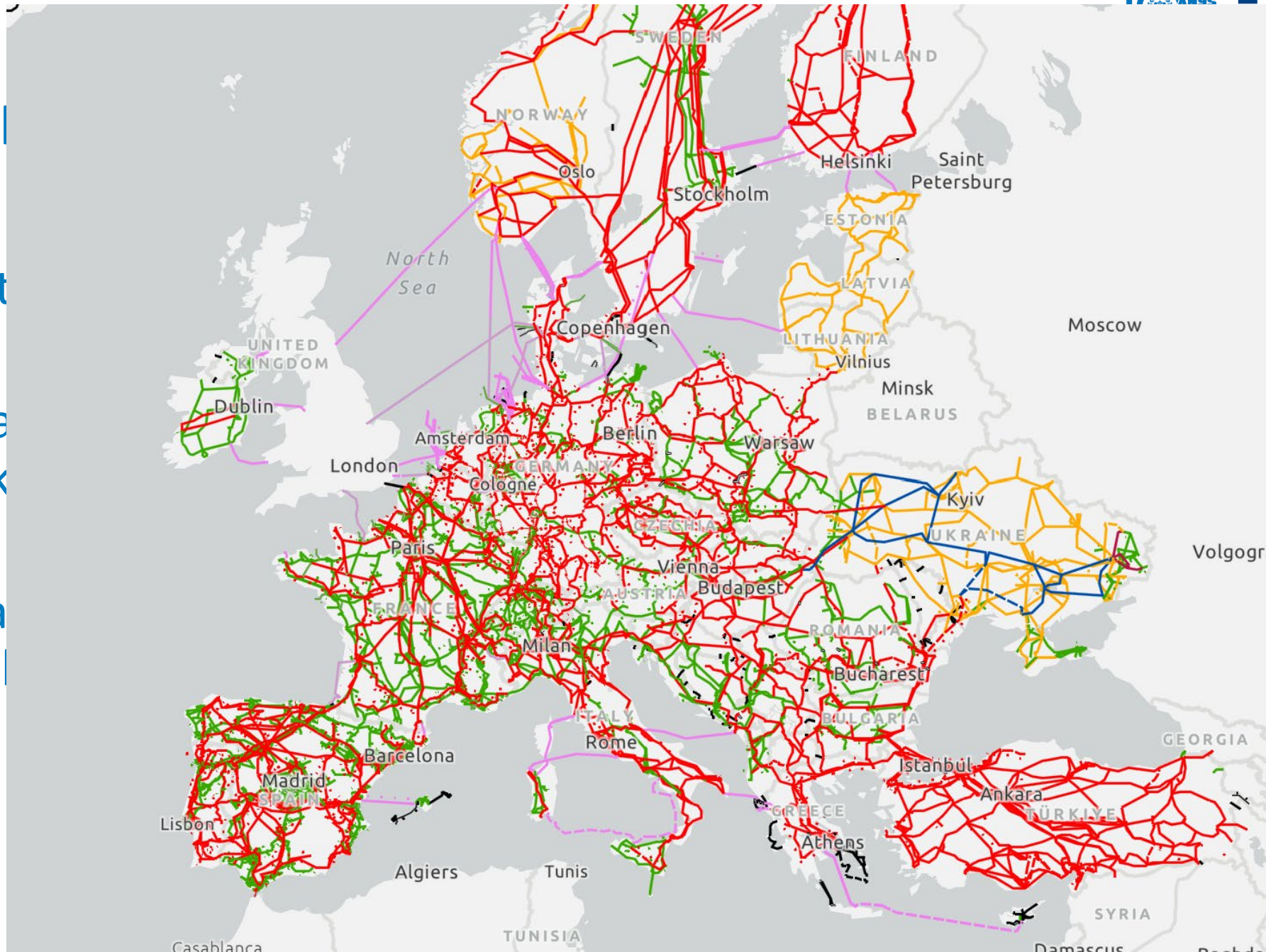

Font: REE

Convertidors - VSC - MMC



Convertidors - VSC - MMC

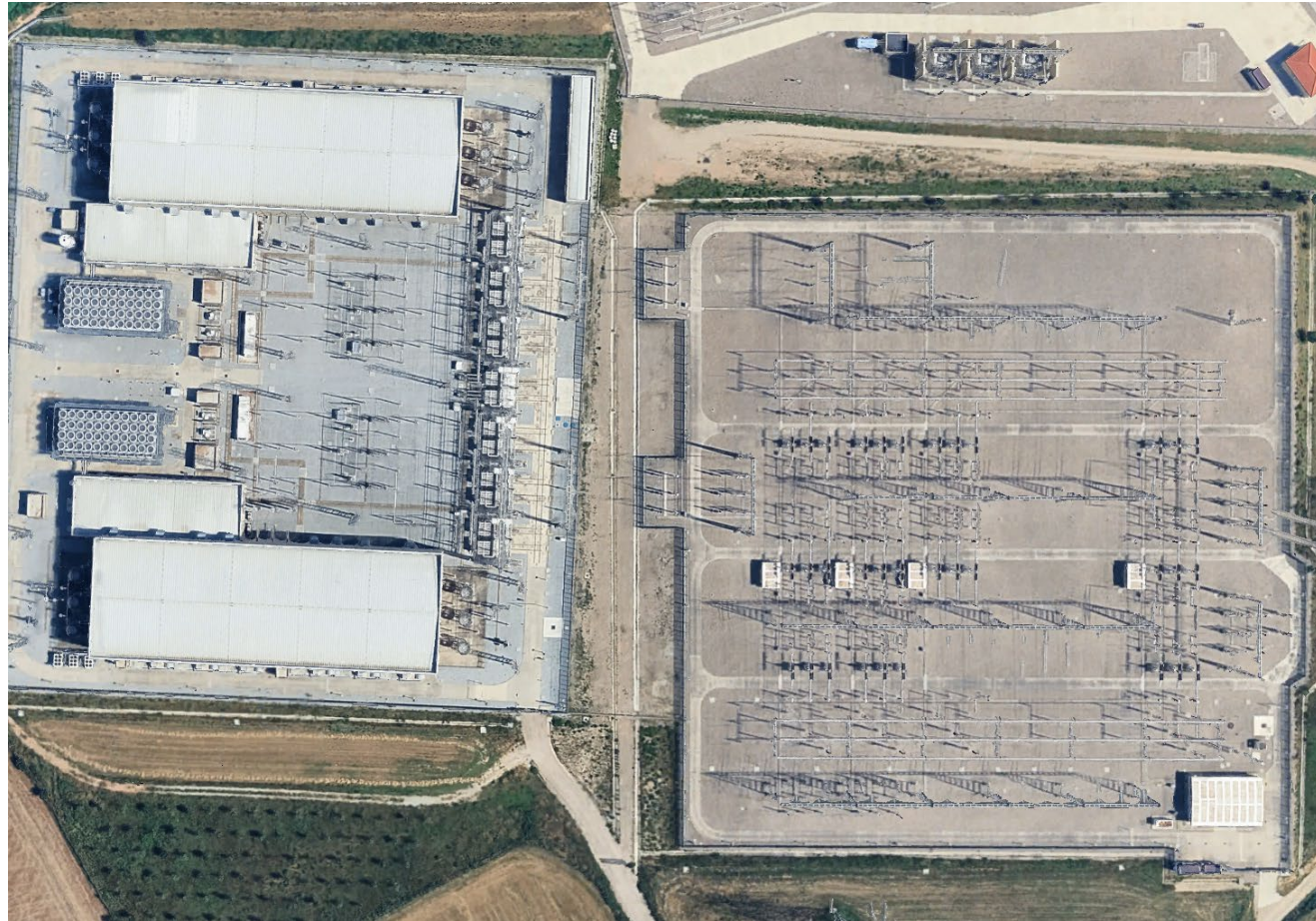

Convertidors - VSC - MMC



Convertidors - VSC - MMC

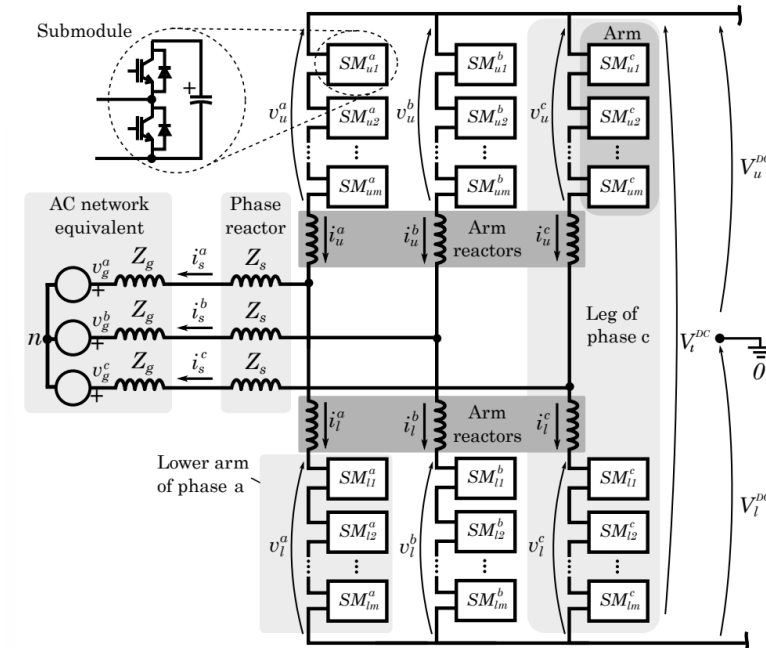

Font: Tesis Eduardo Prieto Araujo

Convertidors - VSC - MMC



Convertidors - VSC - MMC





UNIVERSITAT POLITÈCNICA
DE CATALUNYA
BARCELONATECH



CITCEA UPC
Boosting the future of energy



TECHNOLOGY CENTER
UNIVERSITAT POLITÈCNICA
DE CATALUNYA
BARCELONATECH



Projectes CITCEA

20 d'abril 2026, Barcelona

Jaume Girona Badia
Jaume.girona@upc.edu

Marc Cheah Mañe, Macia Capo Lliteras, Alejandro Alvarez i Farriols,
Jordi Béjar Rabascall, Eduardo Prieto-Araujo and Oriol Gomis-Bellmunt



Funded by
the European Union



Engineers
Industrials de Catalunya

Presentació dels grups de recerca

CITCEA UPC

Centre d'Innovació Tecnològica en Convertidors Estàtics i Accionaments

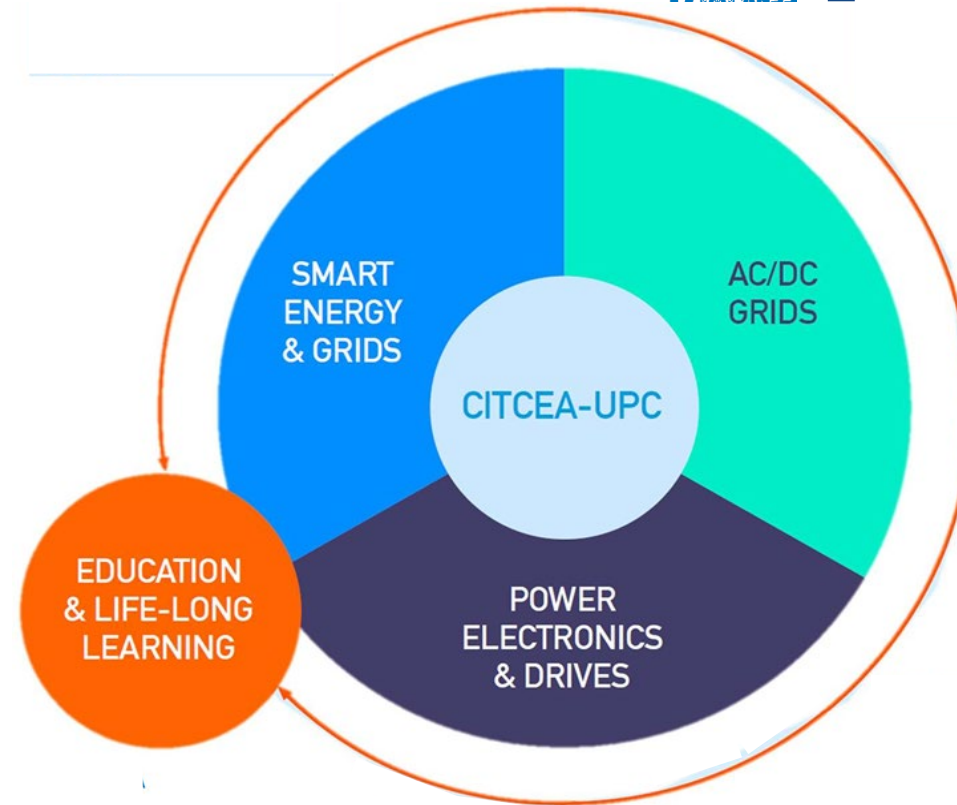
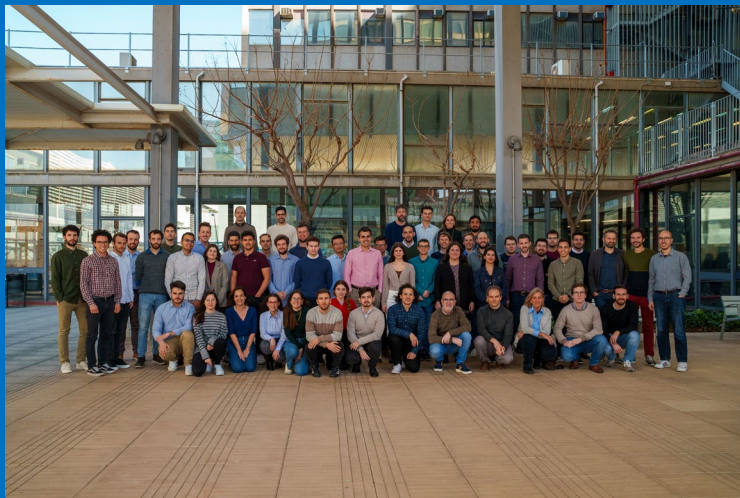

2025

Projectes actuals



22

Patents



18



18

Facturació



4,5 M€

85

Persones

15 Professors

45 Enginyers i Doctorands (PhD)

18 Enginyers en Pràctiques

3 Personal d'administració

Col·laboracions:



red eléctrica



+

> 8 contractes privats

Transferència de talent:





UNIVERSITAT POLITÈCNICA
DE CATALUNYA
BARCELONATECH

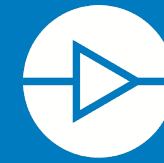

CITCEA UPC
Boosting the future of energy



TECHNOLOGY CENTER
UNIVERSITAT POLITÈCNICA
DE CATALUNYA
BARCELONATECH



Projectes CITCEA

20 d'abril 2026, Barcelona

Jaume Girona Badia
Jaume.girona@upc.edu

Marc Cheah Mañe, Macia Capo Lliteras, Alejandro Alvarez i Farriols,
Jordi Béjar Rabascall, Eduardo Prieto-Araujo and Oriol Gomis-Bellmunt



Funded by
the European Union



Engineers
Industrials de Catalunya

PROSECCO

- En el futur hi ha la possibilitat que apareguin xarxes **HVDC mallades**.
- En una xarxa HVDC mallada el **flux de potència** depèn de les **resistències dels cables**.
- A més, el **flux de potència no** es pot regular amb **potència reactiva** com en els sistemes HVAC.
- Per tant, en un esdeveniment amb **congestió necessitem un equip** per solucionar-ho.



Font: CITCEA

PROSECCO

PROSECCO - DC PROTECTION, SECURITY, CONTROL AND OPTIMISATION

- **Protecció avançada de la xarxa:** Millora l'estabilitat i la seguretat, també estudiant la protecció selectiva de xarxes HVDC mallades.
- **Gestió intel·ligent de la congestió:** Desenvolupament de programari de flux de potència, maquinari de control i eines d'anàlisi de cost-benefici.



Font: Gemini

PROSECCO - Partners



PROSECCO

Els Power Flow Controllers (PFCs) es presenten com uns equips que poden regular el flux de potència en una xarxa mallada.

- Per tant, serien l'equivalent als FACTS en HVDC.
- Aquests equips es connecten en sèrie, en conseqüència, no han de suportar el diferencial de tensió elevat, reduint així molt les pèrdues d'operació.

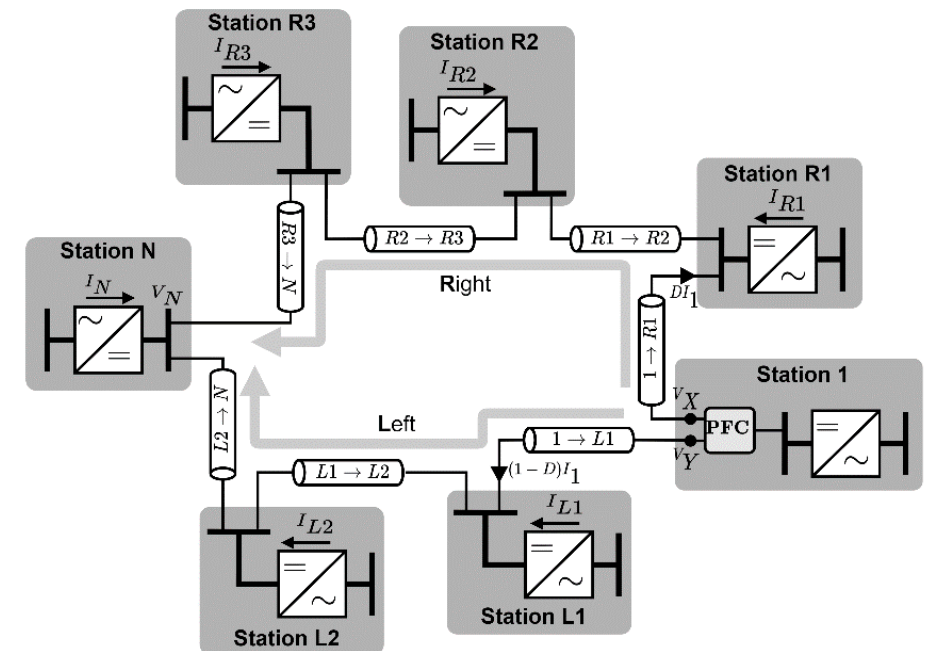

PROSECCO

En el laboratori farem un experiment amb un equip de 1000 A. Per tal d'incrementar el TRL dels PFCs de 4 a 6. Així provant aquests equips en corrent nominal.

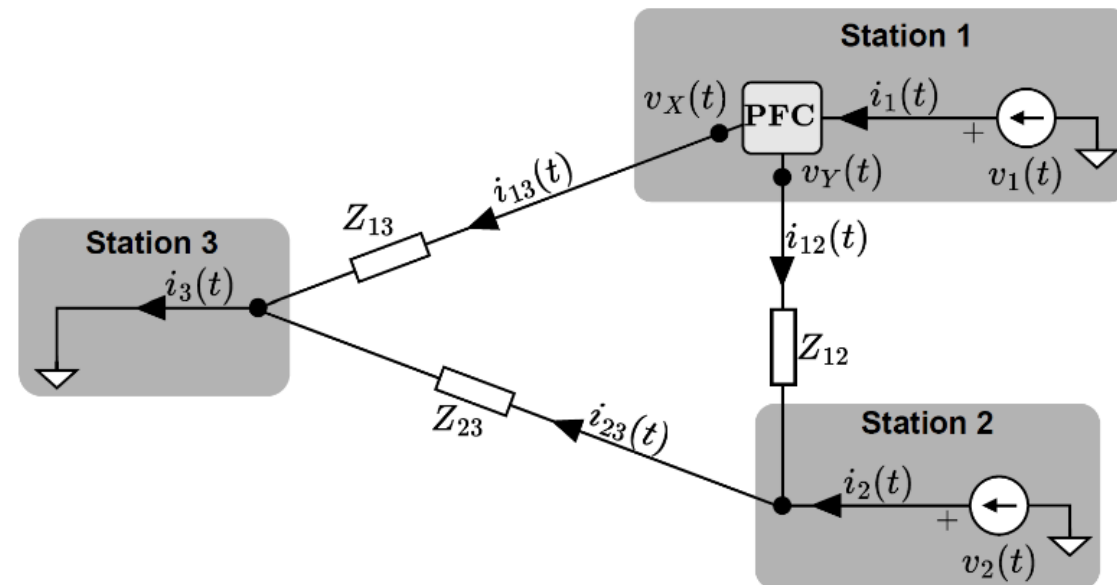
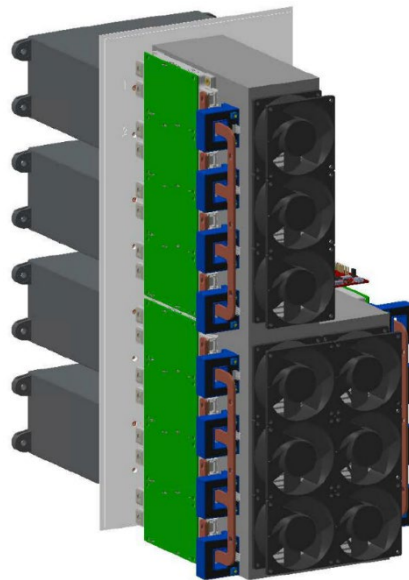



UNIVERSITAT POLITÈCNICA
DE CATALUNYA
BARCELONATECH



CITCEA UPC
Boosting the future of energy



TECHNOLOGY CENTER
UNIVERSITAT POLITÈCNICA
DE CATALUNYA
BARCELONATECH



Gràcies per la vostra atenció

Jaume Girona Badia
jaume.girona@upc.edu

Vinícius Albernaz Lacerda, Matías Uriarte González, Marc Cheah Mañe,
Macia Capo Lliteras, Alejandro Alvarez i Farriols, Jordi Béjar Rabascall, Joan
Marc Rodriguez Bernuz, Eduardo Prieto-Araujo i Oriol Gomis-Bellmunt



Funded by
the European Union

