

Cicle de conferències **Bioenergia i Biomaterials**

Abril – juny 2026

Organitza:



Enginyers
Industrials de Catalunya

amb la col·laboració de:



amb el suport de:



Sessió 1. Biomassa lignocel·lulòsica: Processos Termoquímics

Joan Carles Bruno Argilaguet

Universitat Rovira i Virgili

Dept. d'Enginyeria Mecànica

CREVER – Grup de Recerca en Enginyeria Tèrmica Aplicada

juancarlos.bruno@urv.cat



UNIVERSITAT
ROVIRA I VIRGILI



Grup de Recerca en
Enginyeria Tèrmica
Aplicada



CREVER

Applied Thermal
Engineering
Research Group

CREVER is a multidisciplinary research group at URV that carries out **research and postgraduate training activities** in Energy Polygeneration Systems applied to industrial processes, buildings, and mobility, with the aim of achieving high energy efficiency and use of renewable energies.

Developing technological solutions from basic thermophysical properties measurement to final real implementation and monitoring.



ENERGY EFFICIENCY AND
INTEGRATION IN BUILDINGS AND
PROCESSES



THERMODYNAMIC AND
TRANSPORT PROPERTIES IN
FLUIDS OF INDUSTRIAL INTEREST



ENERGY CONVERSION SYSTEMS
AND TECHNOLOGIES



INDEX

- 1 - Biomass and bioenergy concepts**
- 2 – Classification of Biomass**
- 3 - Biomass conversion technologies**
- 4 - Pyrolysis technology, implementation and research**
- 5 – Gasification: Description, gasifying agents and technologies**
- 6 – Gasification applications (Power Generation and Fuels)**
- 7 – Integrated Gasification with Power-to-X and AD**
- 8 – Current gasification projects**
- 9 – Perspectives**
- 10 – Conclusions**

1 - Biomass and bioenergy concepts

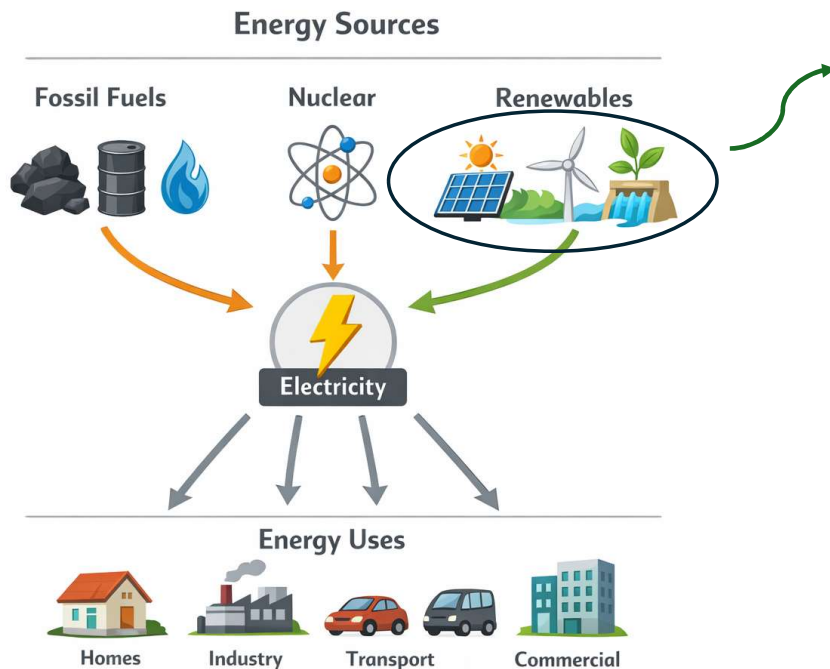

Biomass is a **renewable energy source** (if extraction is not higher than production) **available everywhere** in contrast to many other energy resources.

What is Biomass?

Biomass is organic material that comes from living or recently living organisms. This material is generated from the reaction between the CO_2 of air, water and sunlight (photosynthesis reaction) to produce carbohydrates that are the basis of organic matter in the biological chain.



Examples of biomass (raw biological material):

- Plants (wood, crops, grass)
- Agricultural residues (straw, husks)
- Animal waste (manure)
- Organic waste (food scraps, paper)

What is bioenergy? Bioenergy is the energy obtained from biomass.

Biomass (resource) → conversion → Bioenergy (usable energy)

2 – Classification of Biomass

Biomass is usually classified based on **origin and composition**:

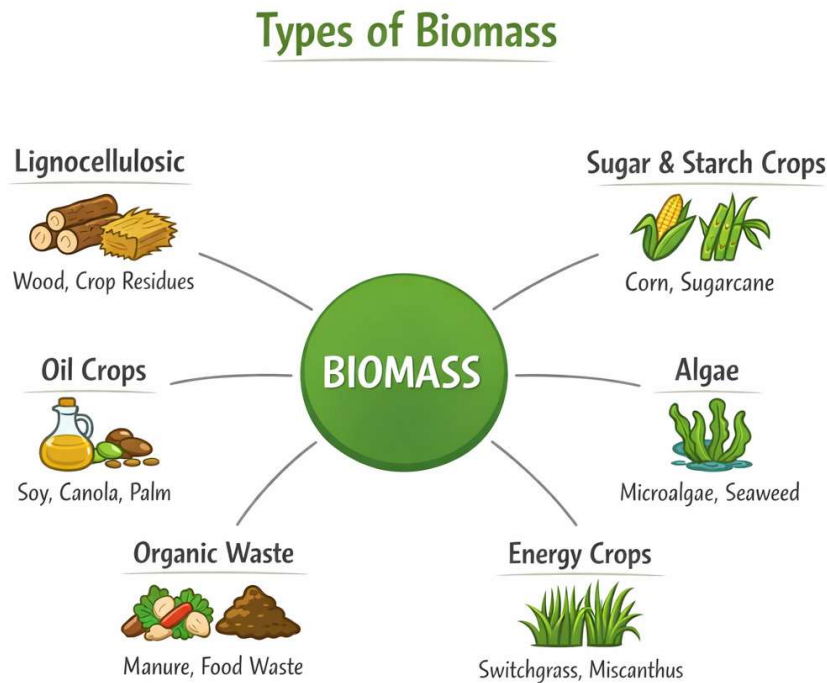

Therefore, Biomass could be classified into **three big families**:

- **Structural (lignocellulosic)** → wood, straw
- **Biochemical (sugars, starch, oils)** → crops
- **Waste & advanced (residues, algae)** → circular sources

According to the **processing**:

- **Raw** (forestry products, crops, animal manure, etc)
- **Secondary** (that undergone significant transformation, such as paper, oils, organic waste, etc).

Why this types of biomass matters for bioenergy ?

Different **types of biomass** →

different conversion processes:

- Sugars/starch → fermentation → ethanol
- Oils → transesterification → biodiesel
- Lignocellulosic → thermochemical conversion → advanced biofuels
- Waste → anaerobic digestion → biogas

3 - Biomass conversion technologies (1/3)

Thermochemical Conversion

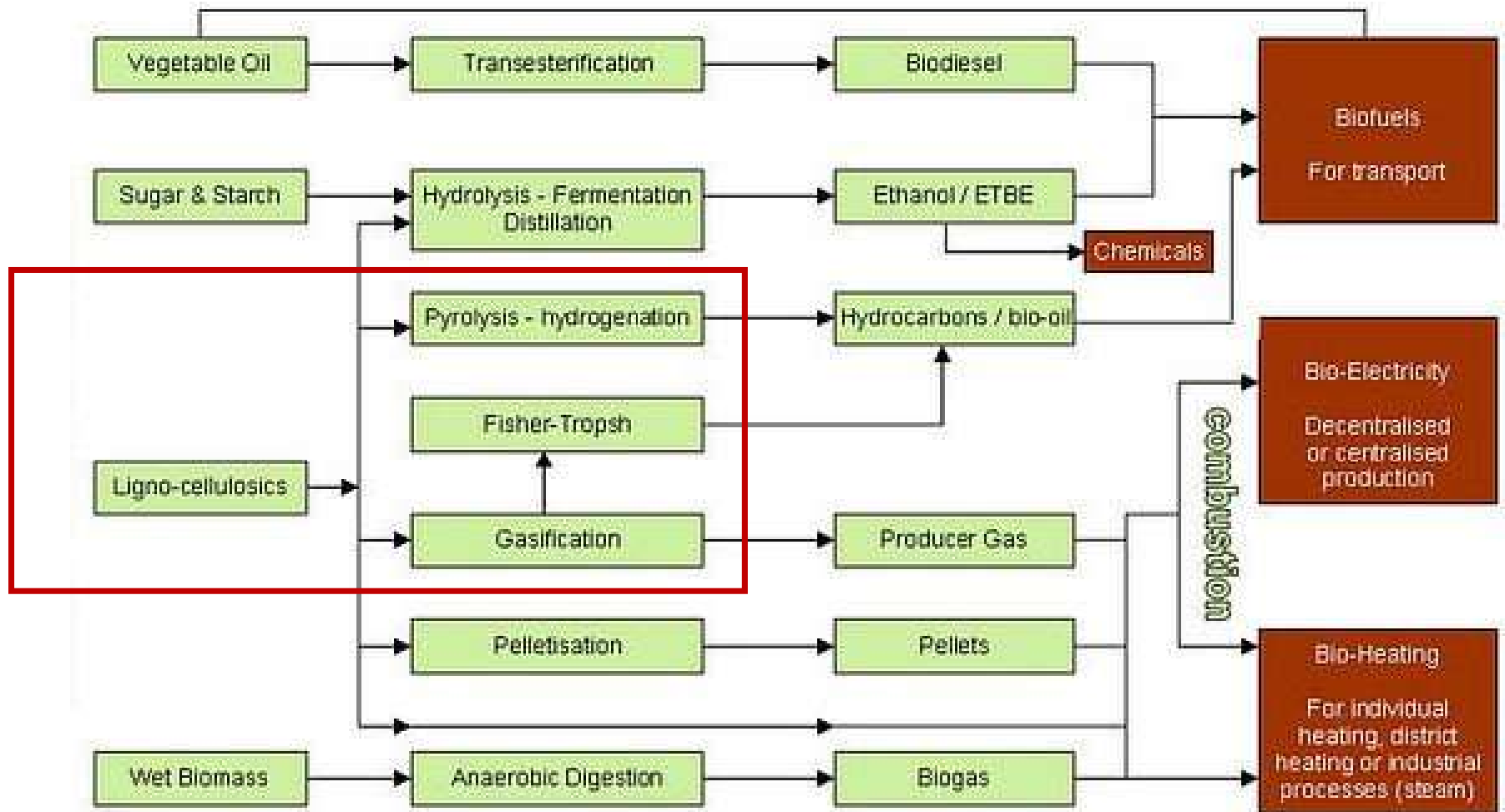

3 - Biomass conversion technologies (2/3)

Biomass-to-Liquids (BtL) – Biojet (SAF, Sustainable Aviation Fuels)

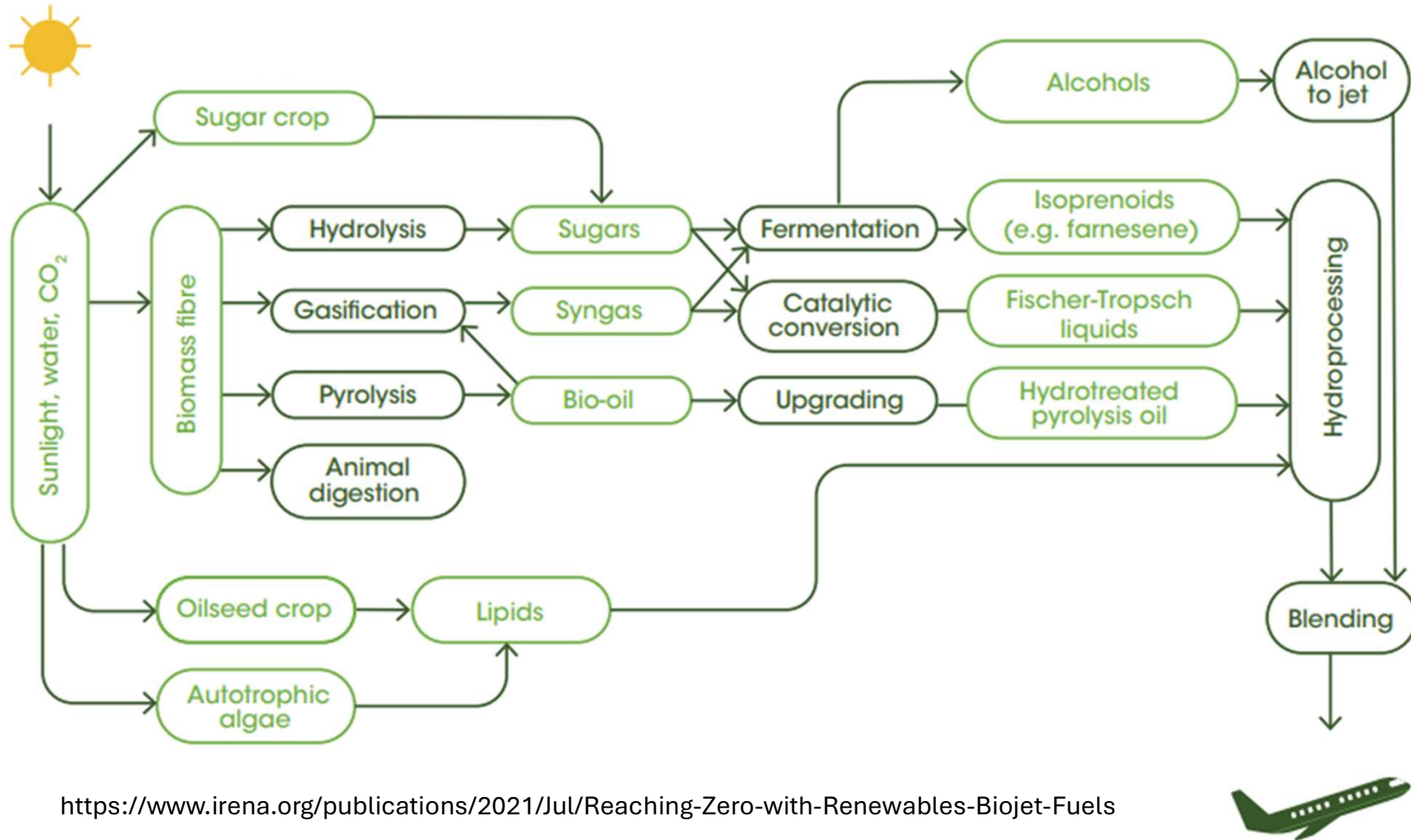

<https://www.irena.org/publications/2021/Jul/Reaching-Zero-with-Renewables-Biojet-Fuels>



3 - Biomass conversion technologies (3/3)

Thermochemical Conversion processes (other than combustion)

	Pyrolysis ^[1]	Gasification ^[1]	Torrefaction ^[2]	Liquefaction ^[3]
T (°C)	250–700	700–1.300	200–300	250–374
P (bara)	1	1–45	≥ 1	20–220
Reaction medium	Inert	Air, oxygen, steam, CO ₂	Inert, oxygen	Water, organic solvents
ER (-)	0	0,2–0,6	≥ 0,2	0
Main reactions	Drying, pyrolysis	Drying, pyrolysis, oxidation, reduction	Drying, mild pyrolysis	Hydrolysis, decarboxylation, dehydration
Gas prod.	Syngas	Syngas		
Liquid prod.	Bio-oil			Bio-crude oil
Solid prod.	Char	Char	Torrefied biomass	Char

^[1] Data from (Recari Ansa, 2017). ^[2] Data from (Mamvura & Danha, 2020). ^[3] Data from (Fan et al., 2023; Lachos-Perez et al., 2022).

Thermochemical conversion refers to processes that use heat, often in combination with chemical reactions, to convert solid biomass into useful fuels or chemicals. When **biomass materials are exposed to heat** (normally above 300°C), an irreversible chemical change occurs and the biomass is transformed into various solid, liquid, or gaseous components.

Torrefaction is a mild, oxygen-free heating process that upgrades biomass into a more energy-dense, coal-like material, often used as a pre-treatment for further conversion.

4 - Pyrolysis technology (1/3)

Pyrolysis: Biomass undergoes conversion at elevated temperatures ($>300^{\circ}\text{C}$) with complete absence of an oxidant.

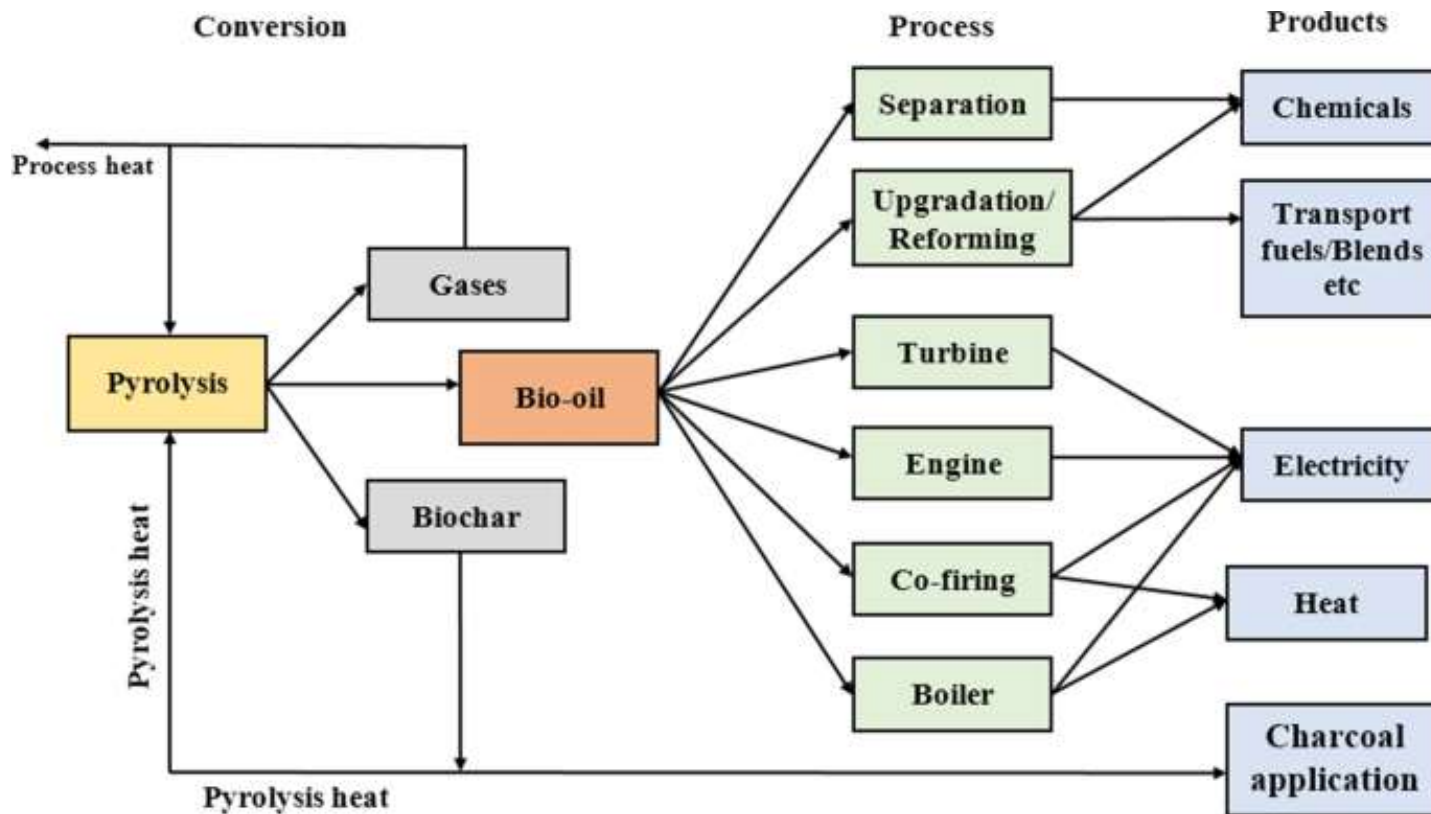

- **Bio-oil** is the main target in many cases
- But **gas and biochar** are definitely used and important
- Modern systems aim to utilize all three fractions efficiently

Biomass pyrolysis technologies for value-added products: a state-of-the-art review
A. N. Amenaghawon, C. L. Anyalewechi, C. O. Okieimen & H. Septya Kusuma
Environment, Development and Sustainability, 23, 14324–14378 (2021).

4 - Pyrolysis technology (2/3): Classification of Pyrolysis methods

Mode	Conditions	Liquid	Solid	Gas
Fast	Reactor temperature 500°C, very high heating rates > 1000°C/sec, short hot vapour residence ~1 s	75%	12% char	13%
Intermediate	Reactor temperature 400-500°C, heating rate range 1 – 1000°C/sec, hot vapour residence ~10-30 s	50%	25% char	25%
Slow – Torrefaction	Reactor temperature ~290°C, heating rate up to 1°C/sec, solids residence time ~30 min	0-5%	77% solid	23%
Slow – Carbonisation	Reactor temperature 400-500°C, heating rate up to 1°C/sec, long solid residence hrs – days	30%	33% char	35%

Torrefaction → very mild
Slow pyrolysis → char-oriented
Intermediate → mixed products
Fast pyrolysis → liquid-oriented

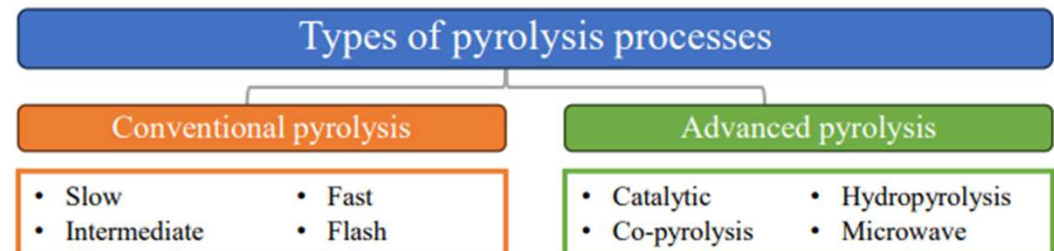

4 - Pyrolysis technology (3/3) – Current implementation

There are some **commercial pyrolysis plants** operating worldwide that process various types of waste at an industrial scale converting biomass, plastics, and tires into bio-oil, biochar, and combustible gases.

Examples of operating commercial plants

- **Empyro (Netherlands):** It was the world's first commercial **fast pyrolysis bio-oil plant at full scale**, operational since 2015. It produces approximately 20 million liters of bio-oil per year from **forestry residues**.
- **Green Fuel Nordic (Finland):** A commercial bio-oil refinery in Lieksa that processes about **90,000 m³ of biomass** annually to produce 24,000 tons of bio-oil.
- **Pyrocell (Sweden):** A joint facility by Setra and Preem that began production in September 2021 to produce sustainable biofuels for the automotive sector.
- **Plants in China and the USA:** Manufacturers such as Beston Group and Splainex Ecosystems have deployed dozens of commercial systems in countries like China, the USA, Germany, and Spain for **recycling plastics and tires**.

Capacity and profitability: Commercial plants are generally classified according to their daily processing capacity:

- **Batch plants:** Process between 5 and 15 tons per day, ideal for small local operations.
- **Continuous plants:** Designed for large volumes (20 to over 100 tons/day), operating with a material conversion efficiency above 85%.

Currently, it is estimated that more than 62% of these plants are designed to handle plastic and rubber waste, as they offer a competitive return on investment (ROI).

4 - Pyrolysis technology – Research experience at CREVER - URV



Escuela Superior
Politécnica de Chimborazo

Prof. Paul Palmay Paredes



Catalytic pyrolysis of recycled polypropylene using a regenerated FCC catalyst
Palmay, P., Medina, C., Donoso, C., Barzallo, D., Bruno, J.C.
Clean Technologies and Environmental Policy Open source preview, 2023, 25(5),
pp. 1539–1549

Bio Oil as Cutter Stock in Fuel Oil Blends for Industrial Applications
Palmay, P., Puente, C., Haro, C., Bruno, J.C., Coronas, A.
Energies, 2023, 16(3), 1485

Production and Analysis of the Physicochemical Properties of the Pyrolytic
Oil Obtained from Pyrolysis of Different Thermoplastics and Plastic Mixtures
Palmay, P., Haro, C., Huacho, I., Barzallo, D., Bruno, J.C.
Molecules, 2022, 27(10), 3287



ESCUELA
POLITÉCNICA
NACIONAL

Prof. Caterine Donoso Quimbita

PhD Thesis in progress:

Estudio de la producción de hidrógeno mediante pirólisis a baja temperatura de biomasa y residuos plásticos empleando catalizadores de Ni-Al₂O₃.
Co-pyrolysis improves yield (less char), fuel quality (closer composition to conventional fuels), and overall process efficiency thanks to chemical interactions between biomass and plastics (higher hydrogen content in plastics).

5 – Gasification: Description, gasifying agents and technologies (1/7)

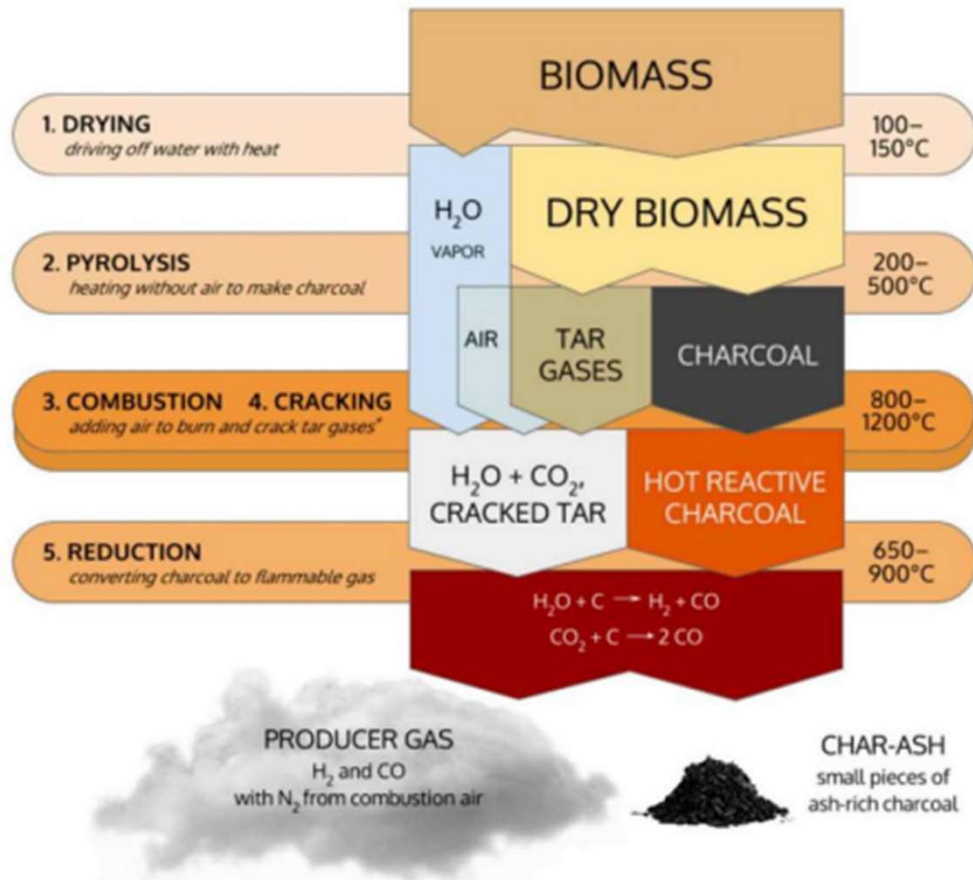

Source: ALL Power Labs, 2024

Gasification is a **partial thermal oxidation** which results in a high proportion of **gaseous products** (CO₂, H₂O, CO, H₂, CH₄, C_xH_y), small quantities of **char, ash and condensable compounds** (tar and oils). The oxidising agents that can be used are air, steam and oxygen. The gasification process takes place at **high temperature** (700°C-1300°C) and needs a supply of oxidant lower than required for a combustion process. The product of the gasification process is a mixture of CO, H₂ and other gases called “**Producer gas**” (low-energy gas for burning) or “**Synthesis gas**” or “**syngas**” (high-quality, versatile chemical feedstock).

Some amount of biomass is converted to tar and char. **Tar** is a complex mixture of condensable organic substances, and is formed in each zone of gasifier, forming the greatest part in pyrolysis zone.

Char is typically produced at the pyrolysis stage and often is the final solid residue left over from gasification process along with the ashes.

5 – Gasification: Description, gasifying agents and technologies (2/7)

History of gasification technology (from Faizan & Song, 2023)

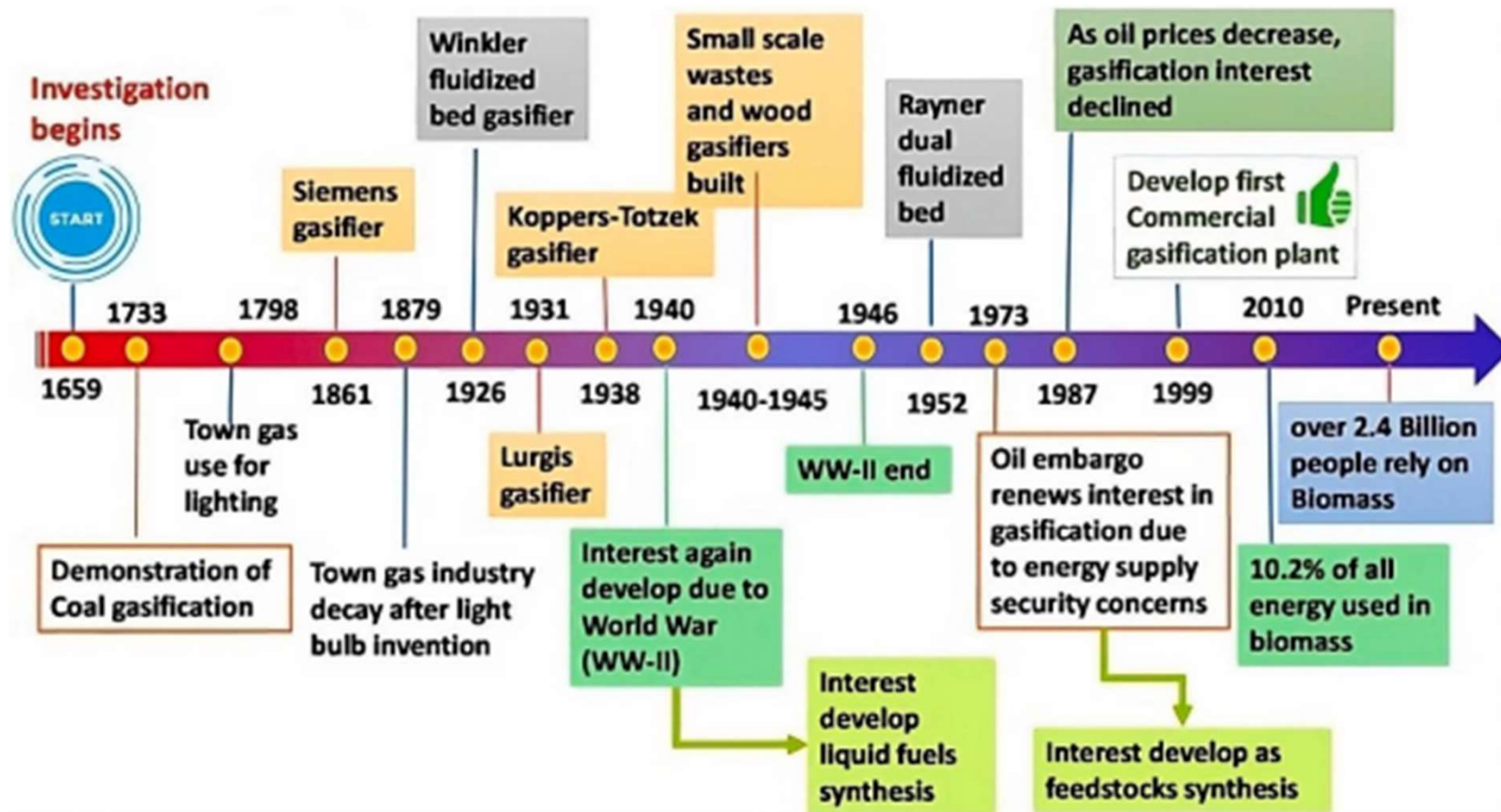

5 – Gasification: Description, gasifying agents and technologies (3/7)

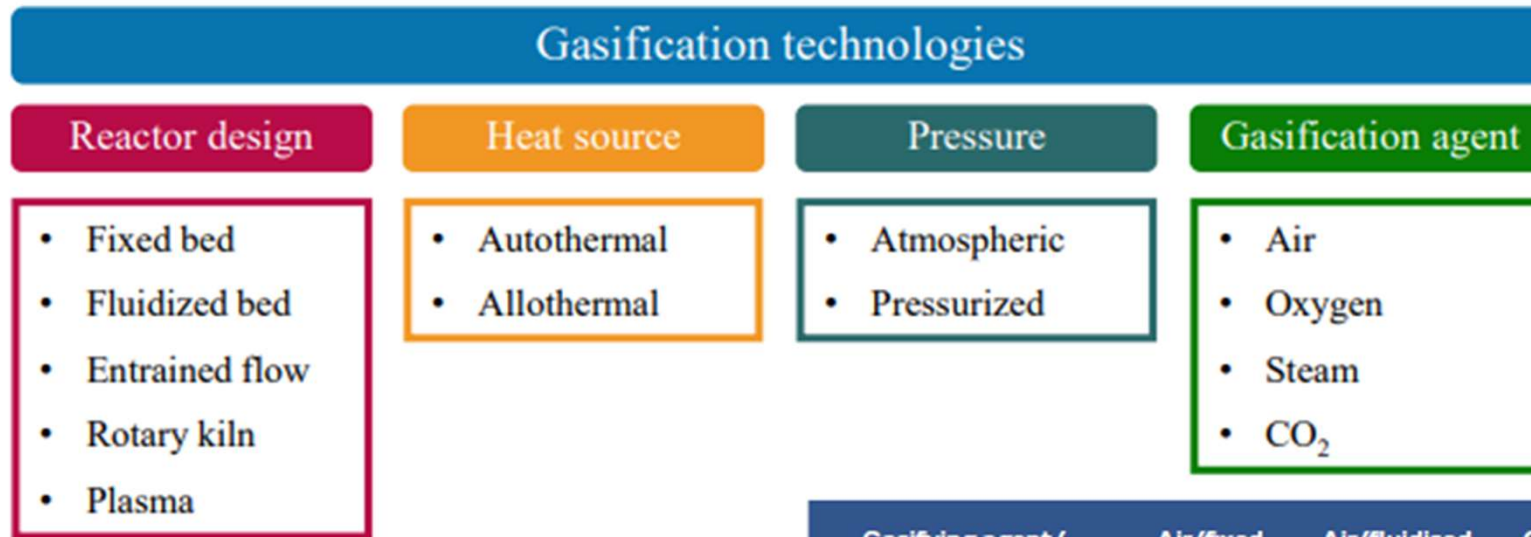

*Renewable gases, Naturgy Foundation,
A. Feliu and X. Flotats, 2020.*

J. Barco-Burgos, J.C. Bruno, U. Eicker, A.L. Saldana-Robles, V. Alcántar-Camarena, Hydrogen-rich syngas production from palm kernel shells (PKS) biomass on a downdraft gasifier using steam as a gasifying agent, Energy Conversion and Management, 245, 114592, 2021.

Gasifying agent/ technology	Air/fixed bed	Air/fluidised bed	O ₂ /fixed bed	Steam/fluidised bed
H ₂ (% vol.)	11 – 17	9 – 14.1	32	34.2 – 52
CO (% vol.)	21 – 24	14 – 18.7	48	23 – 27.2
CO ₂ (% vol.)	9 – 13	13.5 – 20	15	18 – 22.7
CH ₄ (% vol.)	1 – 3	4.5 – 7	2	7 – 11.1
N ₂ (% vol.)	48 – 53	45 – 50	3	≈0 – 4.8
HCV (MJ/Nm ³)	5.5 – 5.7	4.3 – 6.7*	10.4	13.6 – 14.4*

*Values estimated based on composition.

5 – Gasification: Description, gasifying agents and technologies (4/7)

Types of Gasifiers

Modelling Syngas Combustion from Biomass Gasification and Engine Applications: A Comprehensive Review
 Copa et al, 2025, *Energies* 18(19):5112
 DOI: 10.3390/en18195112

Application range of some gasification technologies
 (from Kaur et al., 2019)

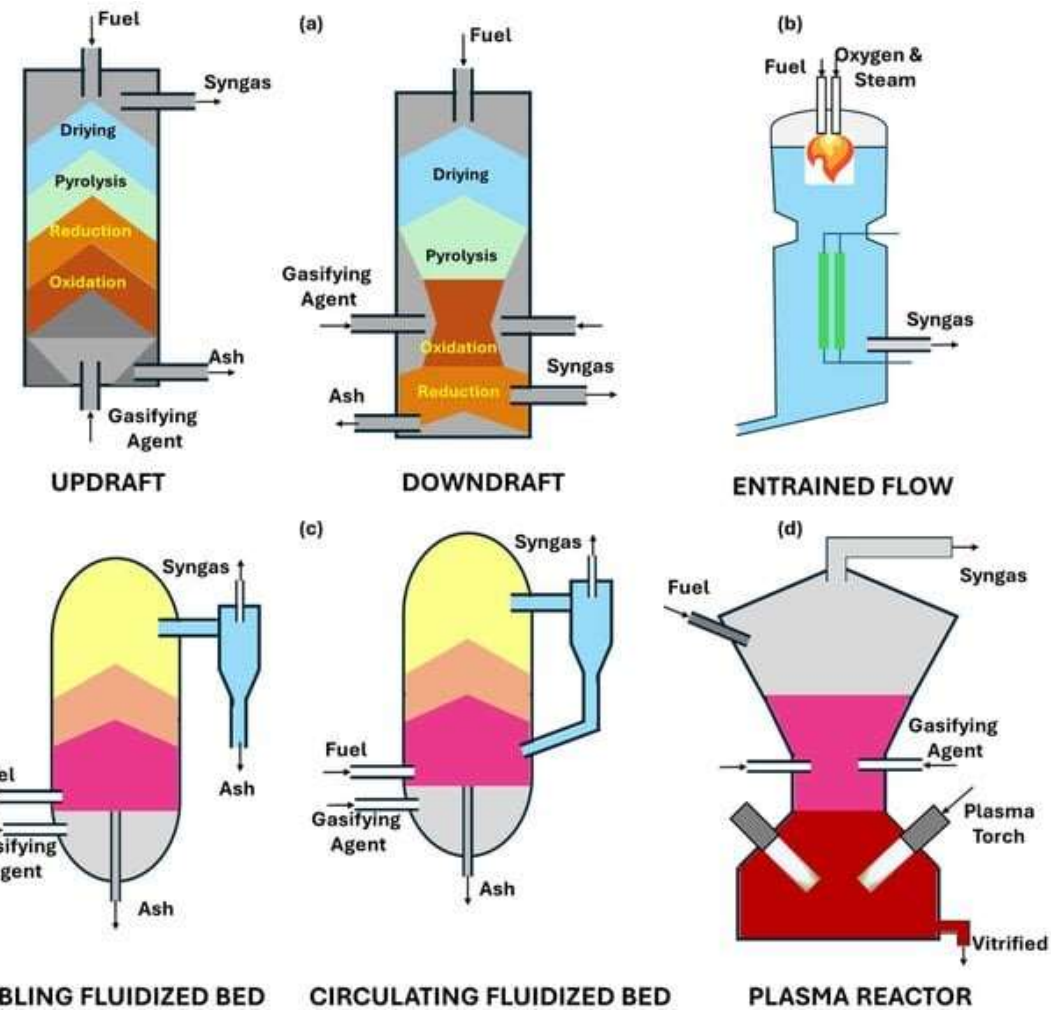
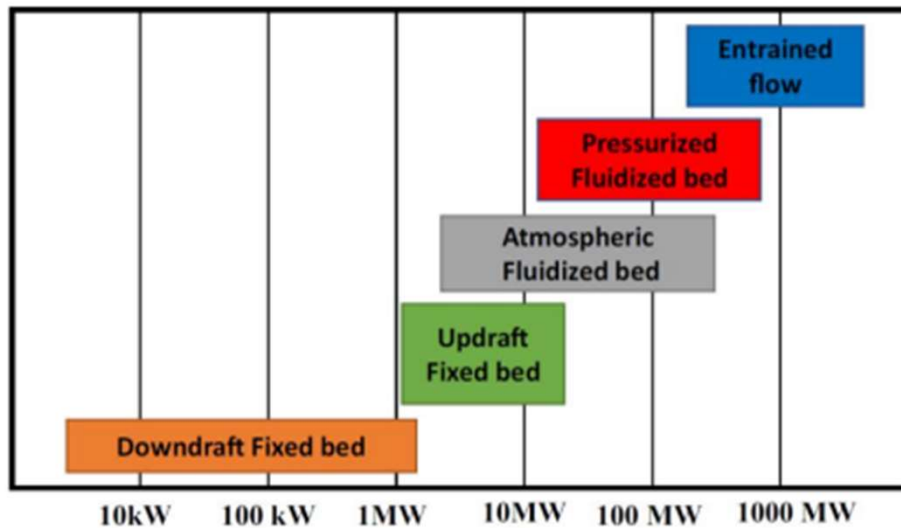

5 – Gasification: Description, gasifying agents and technologies (5/7)

Main reactions during the process of gasification.

	Reaction	Energy profile
Combustion		
Complete	$C + O_2 \rightarrow CO_2$	1 Exothermic
Partial	$C + \frac{1}{2}O_2 \rightarrow CO$	2 Exothermic
Gasification		
	$C + CO_2 \rightarrow 2CO$	3 Endothermic
	$C + H_2O \rightarrow CO + H_2$	4 Endothermic
	$C + 2H_2 \rightarrow CH_4$	5 Exothermic
"Shift" Reaction		
	$CO + H_2O \rightarrow CO_2 + H_2$	6 Exothermic
Methanisation		
	$CO + 3H_2 \rightarrow CH_4 + H_2O$	7 Exothermic

The **composition of the gas** obtained from a gasifier depends on a number of parameters, such as fuel composition, gasifying medium, operating pressure, temperature, moisture content of the fuels, gasifier design, etc. LHV: 4 MJ/Nm³ and 7 MJ/Nm³, with air as oxidizing agent.

Oxidant Agent	H ₂	CO	CO ₂	CH ₄	N ₂	C ₂	Use
Air	16	20	12	2	50	-	Fuel
Oxygen	32	48	15	2	3	-	Fuel / Chemicals
Steam	50	20	22	6	-	2	Fuel / Chemicals

5 – Gasification: Description, gasifying agents and technologies (6/7)

Characteristics of gasification process models

(adapted from Silva et al., 2019).

TFM Manel Martin, URV, 2024.

Model	Characteristics	Limitations
Thermo-dynamic equilibrium	Solve a series of thermodynamic equilibrium equations, which may or may not involve mass and energy conservation equations.	Assume the state of equilibrium. It does not consider the effects of hydrodynamics and geometry.
Kinetic	It studies the progress of the reactions along the reactor, giving the composition of the syngas at different points in the gasifier, taking into account both the geometry and the hydrodynamics of the reactor.	It constrains the geometry by assuming simple reactor hydrodynamics. Results very sensitive to selected empirical kinetic parameters.
ANN	It solves a mathematical regression to correlate the input and output parameters of experimental data, without taking into account the thermodynamic equilibrium or the kinetics involved in the process.	It requires a large amount of data from experiments. Accurate results only for conditions similar to the experimental data used for training.
CFD	It is based on models (Euler type) that involve fluid mechanics, to solve a series of equations of conservation of mass, energy and momentum, in a given region of the gasifier.	It requires specialized software and great computing power. For a good prediction, well-known reactor hydrodynamics are required.
Process simulation	It uses a sequence of approximations dividing the process into sub-processes to solve a series of equations based on thermodynamic or kinetic equilibrium models.	It requires specialized software. Depending on the equations used, the results are similar to thermodynamic or kinetic equilibrium models.

Note: ANN: Artificial neural network. CFD: Computational fluid dynamics.

5 – Gasification: Description, gasifying agents and technologies (7/7)

Thermodynamic Biomass Gasification Model

Biomass data	
Proximate analysis	Ultimate analysis
Ash% = 1,36	m%C _{bio} = 54
FC% = 14,26	m%H _{bio} = 5,6
VM% = 84,38	m%O _{bio} = 38,36
moist% _{wb} = 14,85	m%N _{bio} = 0,24
CH _{1,24} O _{0,53} N _{0,004} S _{0,003}	m%S _{bio} = 0,44
HHV _{exp} = 0 [kJ/kg]	HHV _{bio} = 18977 [kJ/kg]

Tar data		
C2H6		C ₆ H ₆ O _{0,2}

Key parameters	
ER = 0,25 [-]	ω _{char} = 0,0427
Air%O ₂ = 21	Y _{tar} = 2,33 [g/m ³]
AFR = 1,614	Ratio _{OC} = 1,031
SBR = 0	LHV _{syn,vol} = 6,514 [MJ/Nm ³]
loss% = 5	K _{eff} = 56,6 [%]

Syngas flowrates & composition			
	\dot{m} (kg/h)	\dot{V} (m ³ /h)	y (molar)
Total	27,3	119	
H ₂	0,307	16,1	0,136
CO	7,19	27,1	0,230
CO ₂	4,16	9,98	0,085
CH ₄	0,687	4,52	0,038
N ₂	12,4	46,7	0,396
H ₂ O	2,23	13,1	0,111
H ₂ S	0,0468	0,145	1,23E-03
NH ₃	1,26E-03	7,84E-03	6,64E-05
Tar	0,276	0,970	3,04E-03

\dot{V}_{syn} (Nm ³ /h)					
Total	H ₂	CO	CO ₂	CH ₄	N ₂
22,2	3,41	5,75	2,12	0,960	9,92

Show plot

Biomass input
$\dot{m}_{bio,db}$ = 10,0 [kg/h]
$\dot{m}_{bio,wb}$ = 11,6 [kg/h]

Steam input
$\dot{m}_{steam,in}$ = 0,00 [kg/h]
$\dot{V}_{steam,in}$ = 0,00 [m ³ /h]

Air input
\dot{m}_{air} = 16,1 [kg/h]
\dot{V}_{air} = 12,5 [Nm ³ /h]

Syngas output
\dot{m}_{syn} = 27,3 [kg/h]
$\dot{V}_{syn,wb}$ = 119 [m ³ /h]

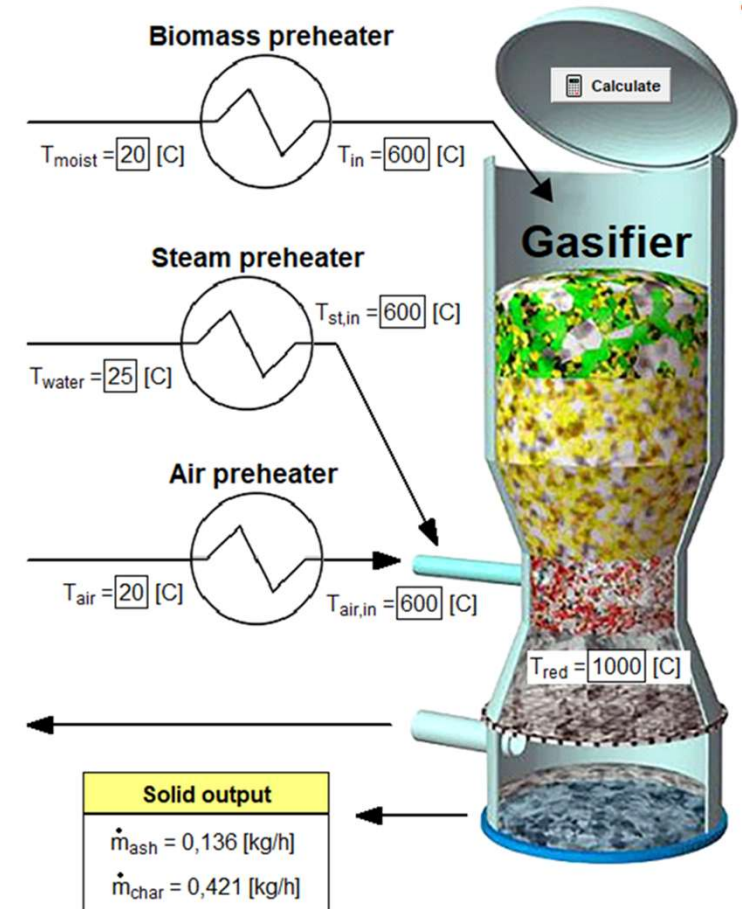

Manel Martin Domenech, Modeling and simulation of the gasification process for the valorization of organic waste using a thermodynamic equilibrium approach, Master Thesis, February 2024.

6 – Gasification applications (1/4)

6.1 – Power generation

GASIFICATION PROCESS IN A POLYGENERATION SYSTEM

M. Puig-Arnavat, Maria; J.C. Bruno, A. Coronas, *Modeling of trigeneration configurations based on biomass gasification and comparison of performance. Applied Energy. 114, 845 – 856, 2014. DOI: 10.1016/j.apenergy.2013.09.013*

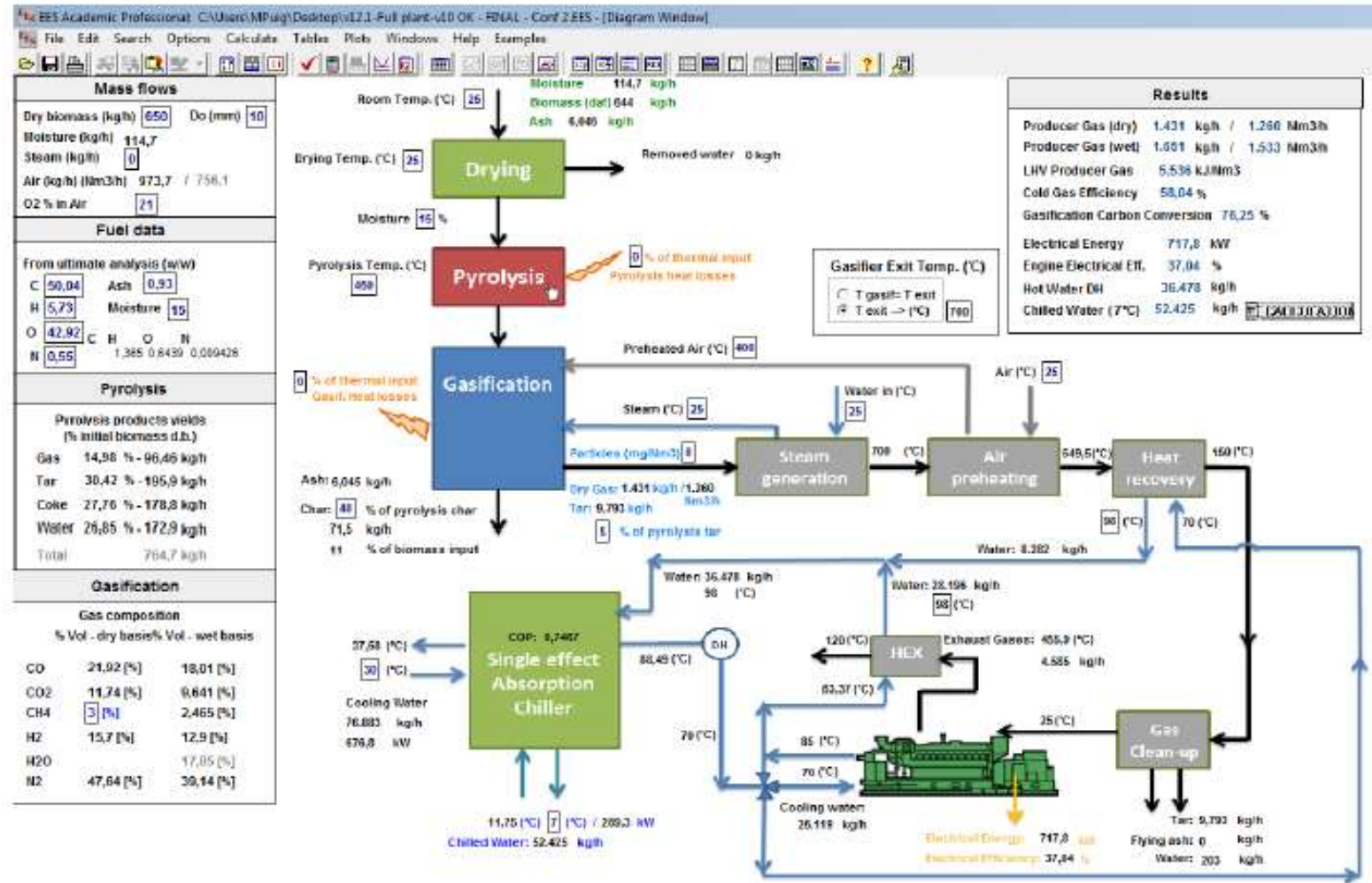

6 – Gasification applications (2/4)

6.2 – Synthetic fuels

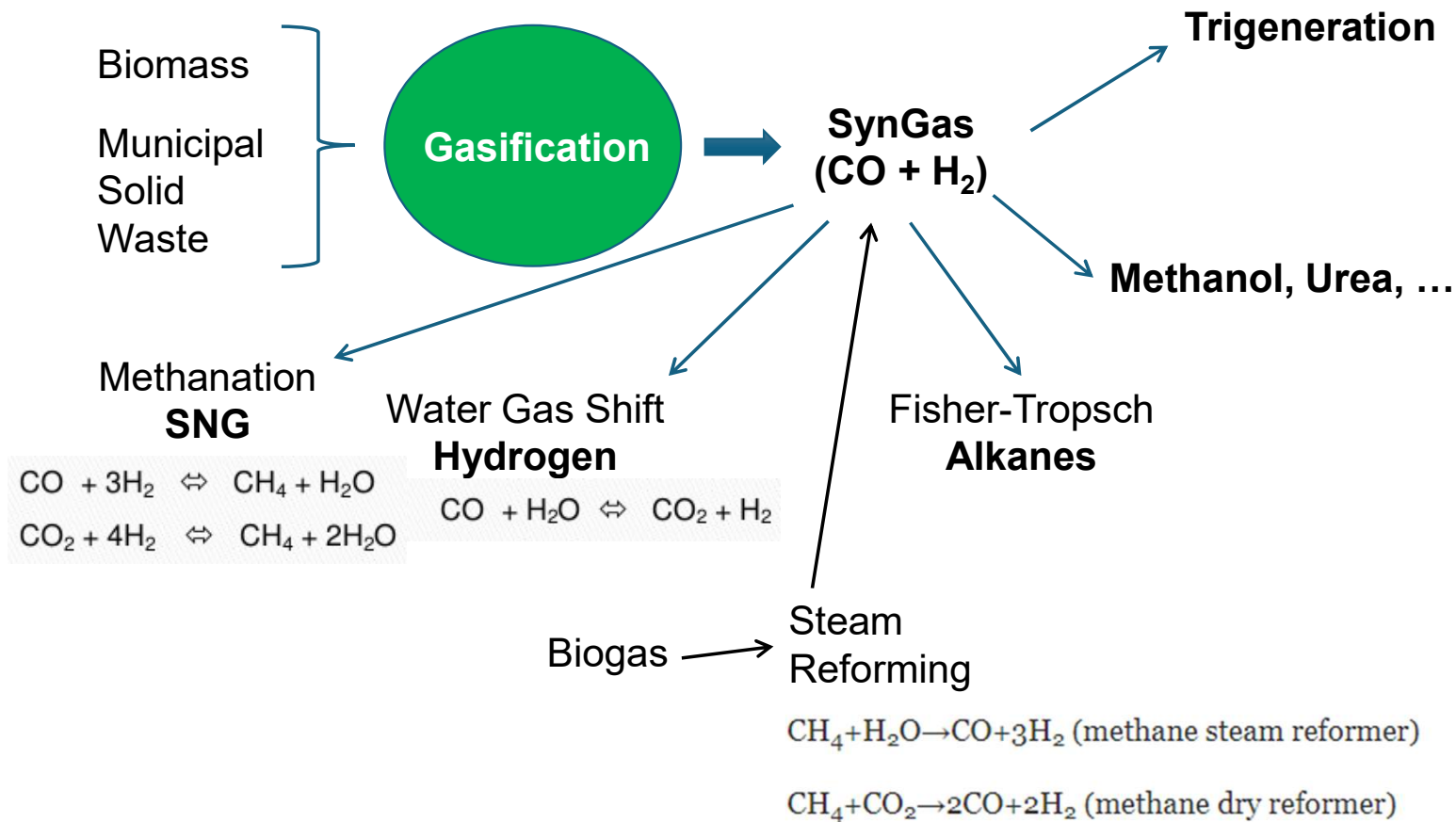

6 – Gasification applications (3/4)

6.3 – Hydrogen generation (1/2)

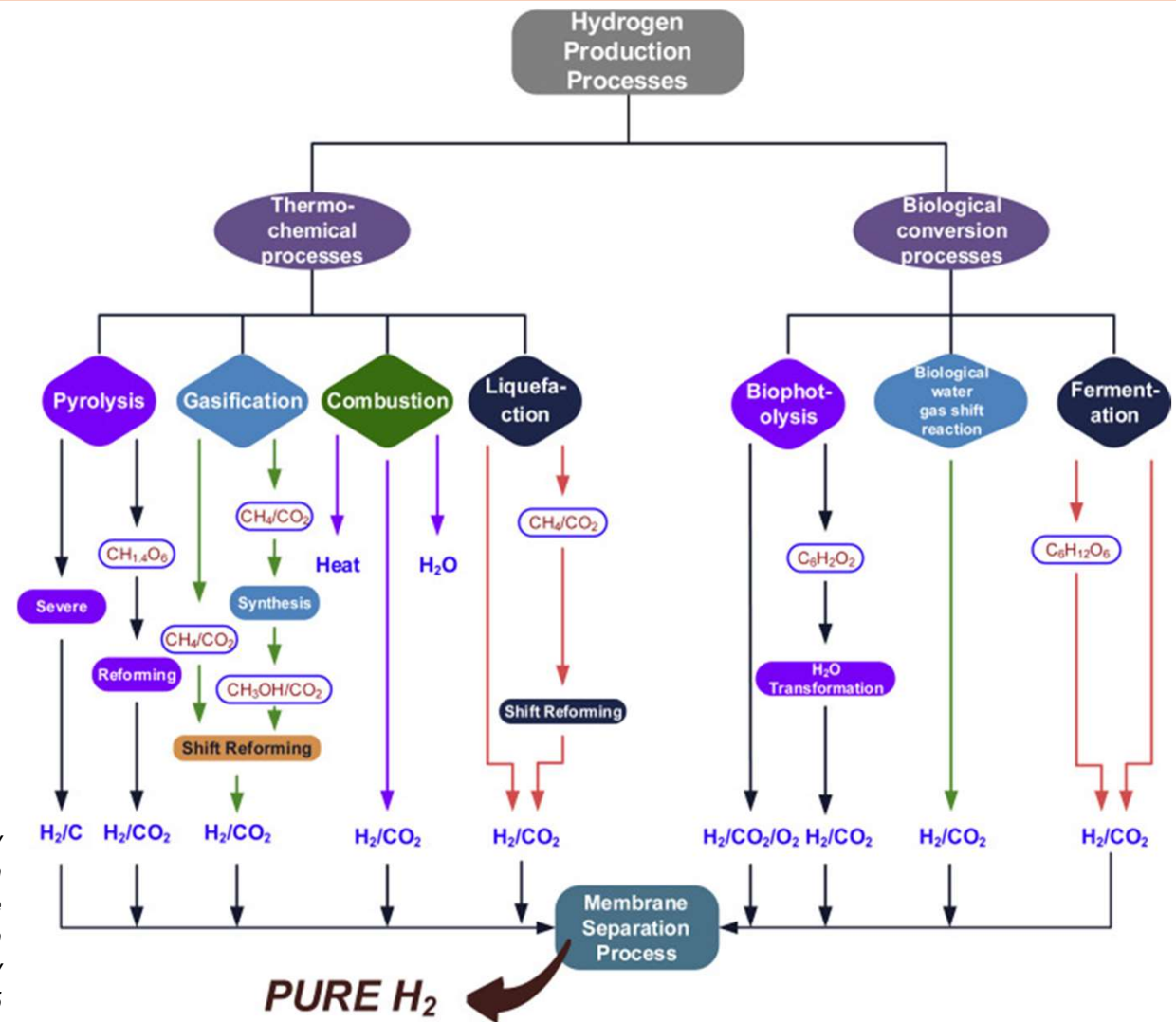

M. Shahbaz, T. Al-Ansari, M. Aslam, Z. Khan, A. Inayat, M. Athar, S. R. Naqvi,
M. A. Ahmed, G. McKay

A state of the art review on biomass processing and conversion technologies to produce hydrogen and its recovery via membrane separation

International Journal of Hydrogen Energy
Volume 45, Issue 30, 29 May 2020, Pages 15166-15195

6 – Gasification applications (4/4)

6.3 – Hydrogen generation (2/2)

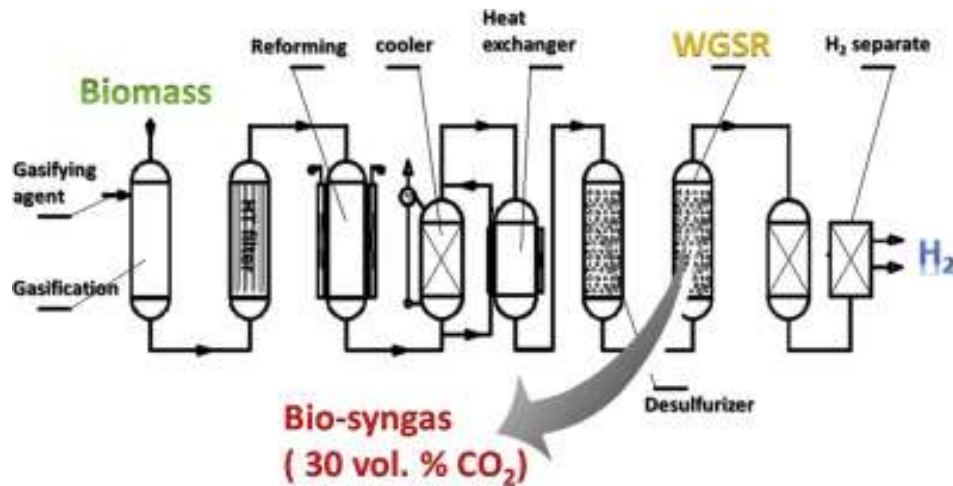

Hsuanyu Chu, et al 2015, <https://doi.org/10.1016/j.ijhydene.2015.01.170>

3) Heat recovery to generate steam.

- Usually a **heat exchanger / waste heat boiler**.
- Steam is reused for:
 - Gasification agent
 - Steam reforming
 - Water-gas shift

4) **Desulfurization** is placed before catalytic steps (like WGS) to prevent catalyst poisoning.

1) **High-temperature filter (hot gas cleanup)**: Remove particulates, char, ash, bed material fines, dust. Operates at high temperature to avoid cooling the gas (which would condense tars).

2) **Tar reforming / Steam reformer**: Convert hydrocarbons into syngas. Typically uses Ni-based catalysts. Favoured by high temperatures.

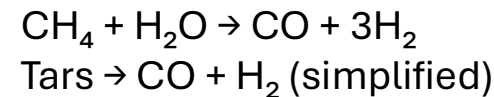

5) **Water-Gas Shift (WGS) reactor**: Increase hydrogen yield.

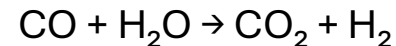

• Often done in **two stages**:

- High-temperature shift (fast bulk conversion of CO)
- Low-temperature shift (polish remaining CO to low levels)

6) **Separation** of CO₂ (ex. amine scrubber) and H₂ (PSA for higher purity).

7 – Integrated Gasification

7.1 – with Power to X (2/2)

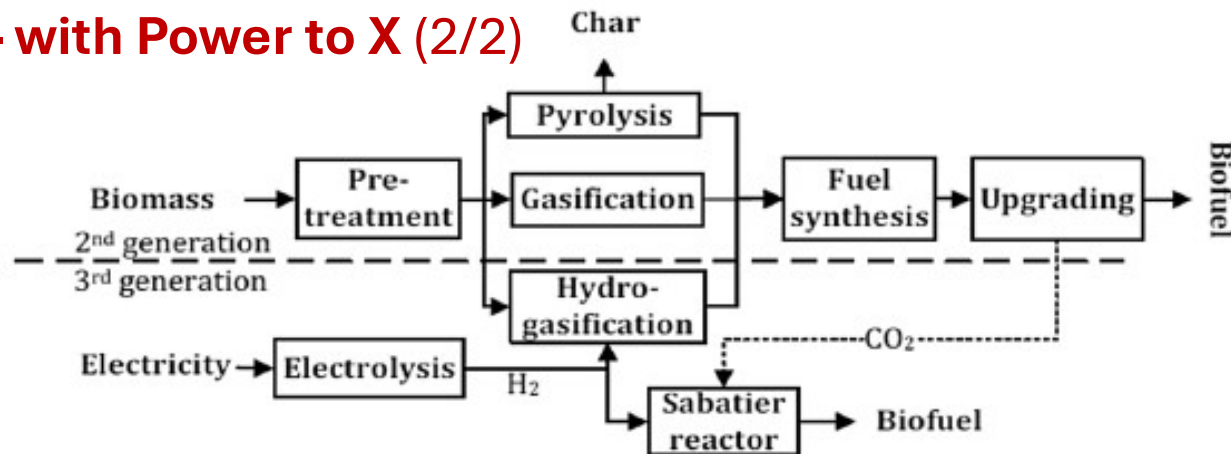

Biomass hydrogasification is a thermochemical process where biomass reacts with hydrogen (H₂) at high temperature (typically 700–1000 °C) and moderate–high pressure to produce a methane-rich gas.

Methanation is a chemical reaction that converts carbon monoxide and/or carbon dioxide to methane. The production of methane across the “Sabatier” reaction (1) was proposed by Paul Sabatier and J.B. Sendersens in 1902. This reaction takes place at a high temperature, around 300°C, and at a pressure of 8-10 bar, in the presence of a catalyst. So far it is not usual because of the good availability and economy of natural gas.



In fact, the Sabatier reaction can be seen as the sum of the CO-methanation with the reverse **WGS (Water Gas Shift reaction)**:



7 – Integrated Gasification

7.2 – with Anaerobic Digestion (1/2)

Integrating anaerobic digestion (AD) with gasification creates a hybrid waste-to-energy system that maximizes resource recovery. AD converts wet organic waste into biogas, while gasification processes the remaining dry digestate into syngas, significantly boosting total energy efficiency and producing valuable synthetic natural gas (SNG).

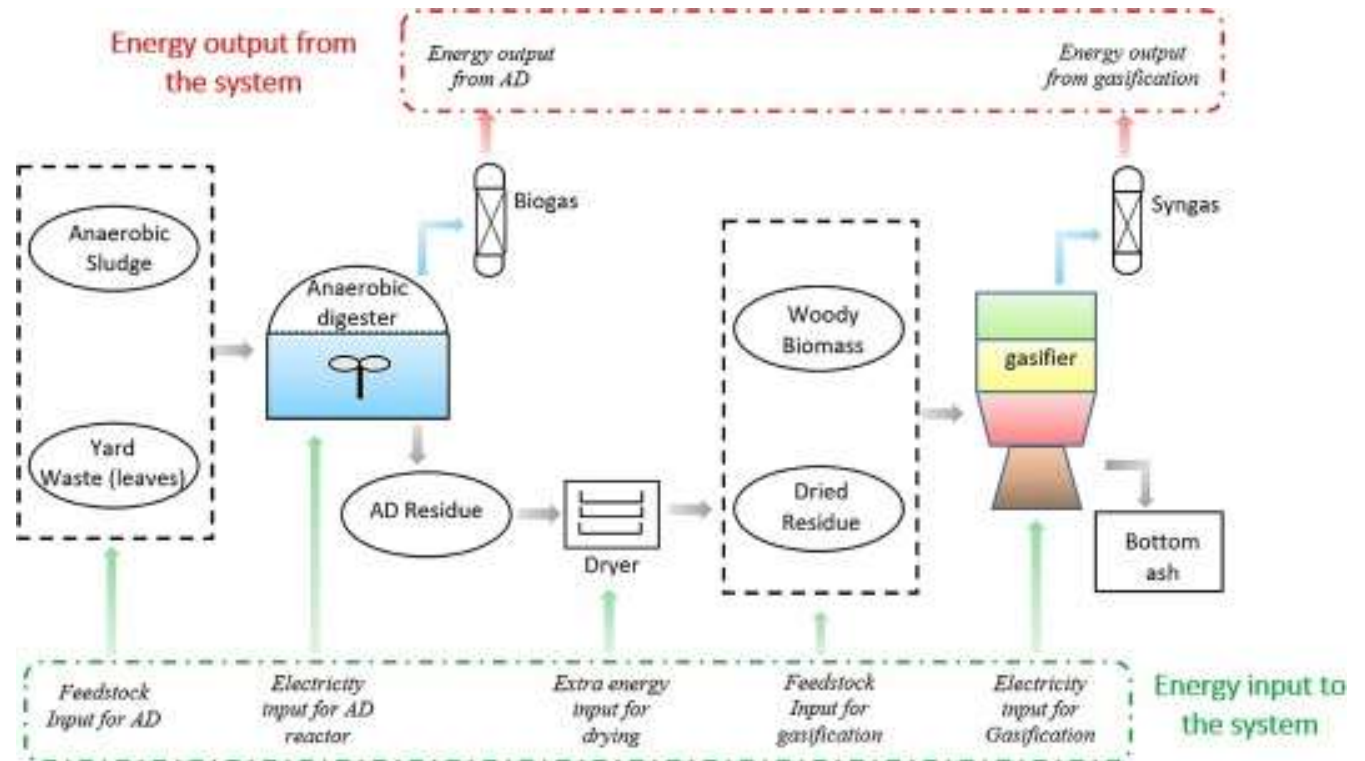

Yao Z., Li W., Kan X., Dai Y., Tong Y. W., and Wang C.-H., Anaerobic Digestion and Gasification Hybrid System for Potential Energy Recovery From Yard Waste and Woody Biomass, *Energy*. (2017) 124, 133–145, <https://doi.org/10.1016/j.energy.2017.02.035>, 2-s2.0-85013131058.

7 – Integrated Gasification

7.2 – with Anaerobic Digestion (2/2)

Integrated anaerobic digestion, thermal gasification, and electrolysis cells for bio-SNG generation

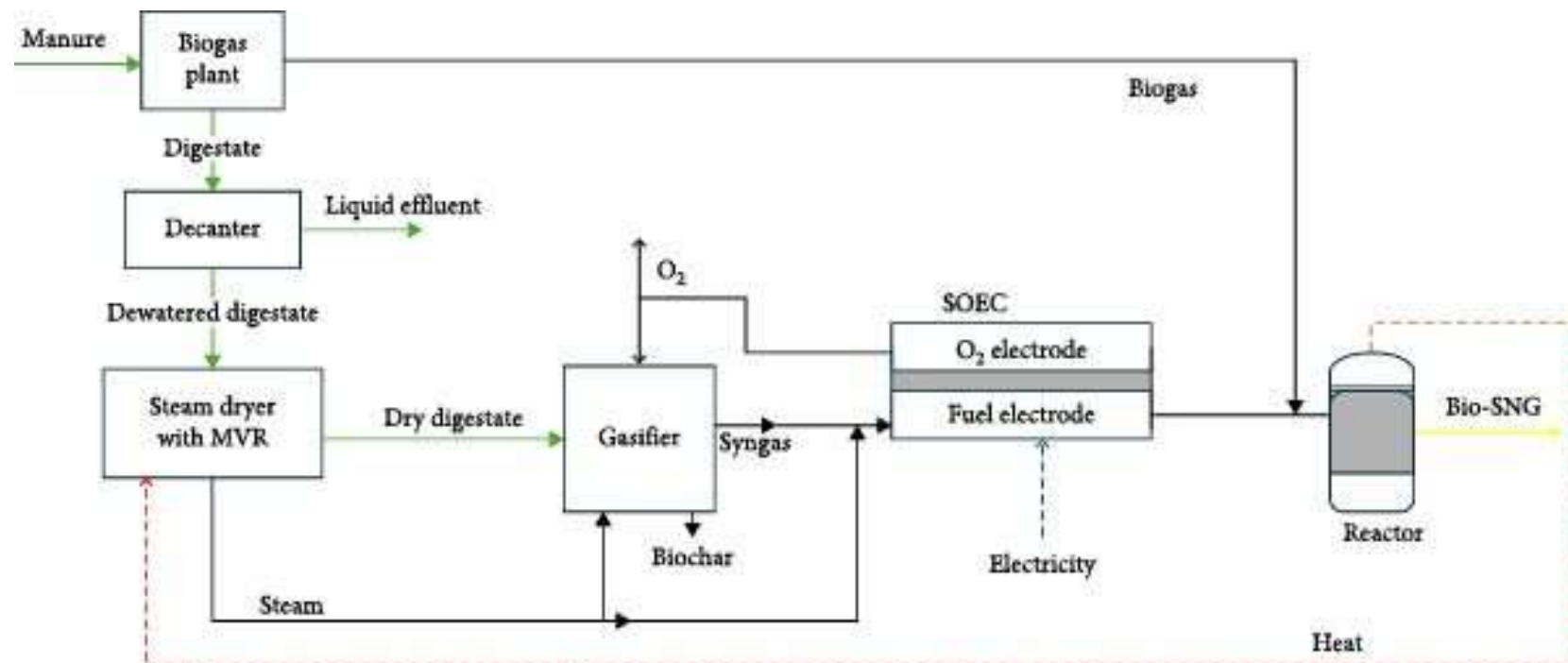

Clausen L. R., Butera G., and Jensen S. H., Integration of Anaerobic Digestion With Thermal Gasification and Pressurized Solid Oxide Electrolysis Cells for High Efficiency Bio-SNG Production, Energy. (2019) 188, <https://doi.org/10.1016/j.energy.2019.116018>, 2-s2.0-85071642248, 116018.

8 – Current projects (1/2)

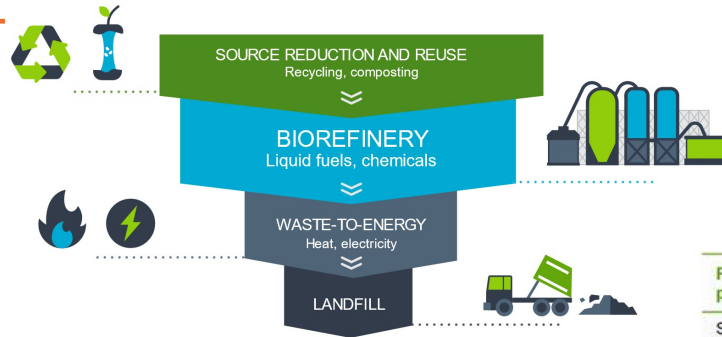

PROJECT PIPELINE WORLDWIDE



Ecoplanta (El Morell, Tarragona)

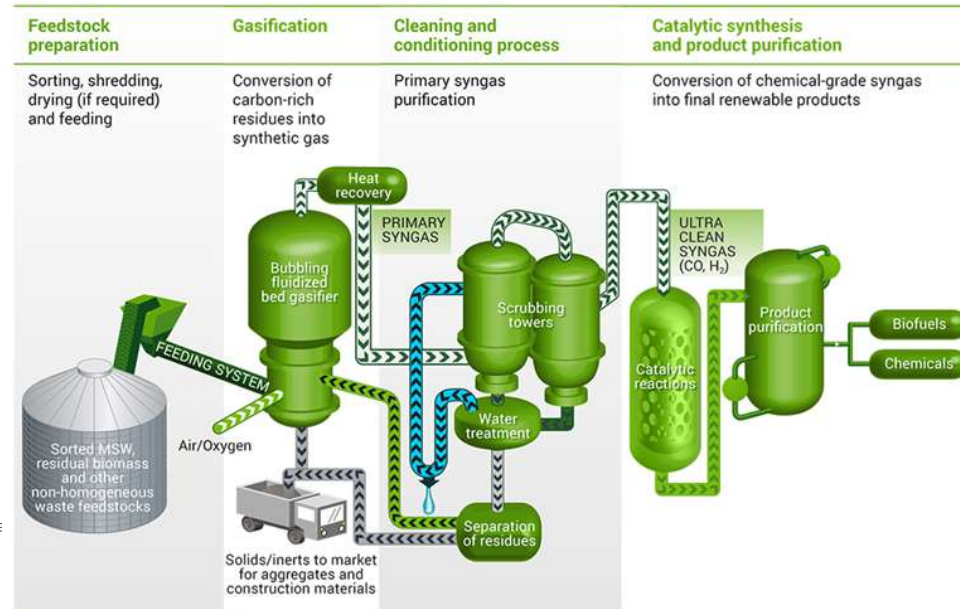

* Municipal solid waste

<p>400,000 tonnes/year</p> <p>waste converted into new circular and bio-products</p>	<p>240,000 tonnes</p> <p>of circular methanol to produce circular materials and advanced biofuels</p>	<p>3.4 Mt</p> <p>CO₂ greenhouse gas (GHG) emissions reductions over the first 10 years</p>	<p>2026 year</p> <p>of start up</p>
---	--	--	--

<https://enerkem.com/>

<https://www.repsol.com/es/sostenibilidad/economia-circular/nuestros-proyectos/valorizacion-residuos-quimica-derivada/index.cshtml>

8 – Current projects (2/2)

A novel multi-stage steam gasification and syngas purification demonstration plant for waste to hydrogen conversion (“HYIELD” EU Project)

<https://hyield.eu/first-hyiel-webinar/>

WtEnergy Cleantech Gasification (patented) R1

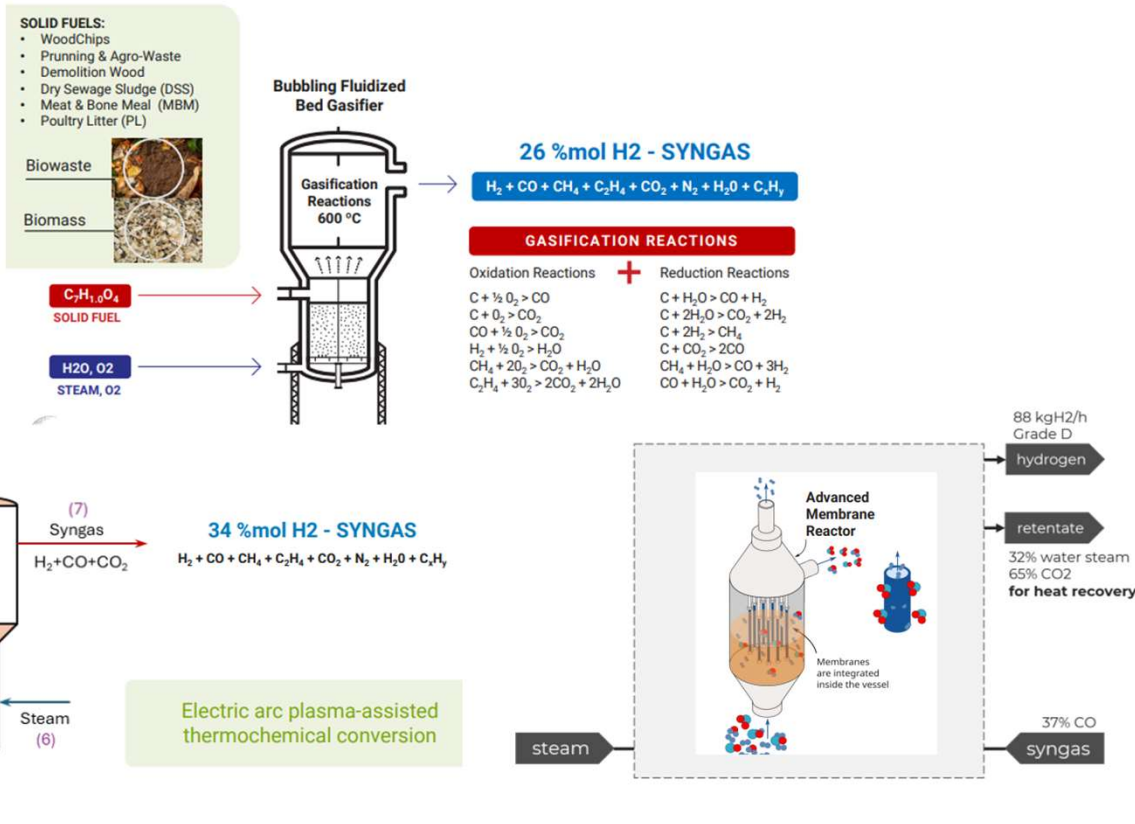

- Conversion of **biogenic waste** streams into high purity green hydrogen.
- The solution is based on a **multi-stage gasification and gas cleaning** process based on the WtEnergy Cleantech
- **Water-gas-shift membrane reactor** from H2Site to upgrade syngas and separate hydrogen (H₂) to achieve >99.97% purity hydrogen.
- **Hydrogen storage** using Metal Hydrides.
- The **demonstration plant** will be implemented at CEMEX’s cement factory in Alcanar (Tarragona), Spain, where the green hydrogen will improve the renewable share of fuel mix in clinker production.

9 – Perspectives

POLYGENERATION SYSTEMS

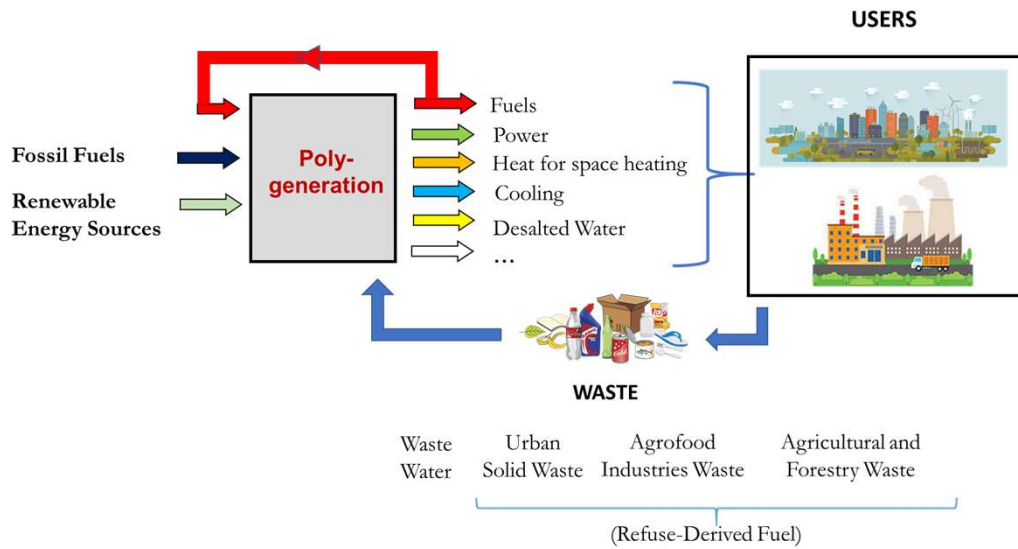

SECTOR COUPLING AND CONVERSION TECHNOLOGIES

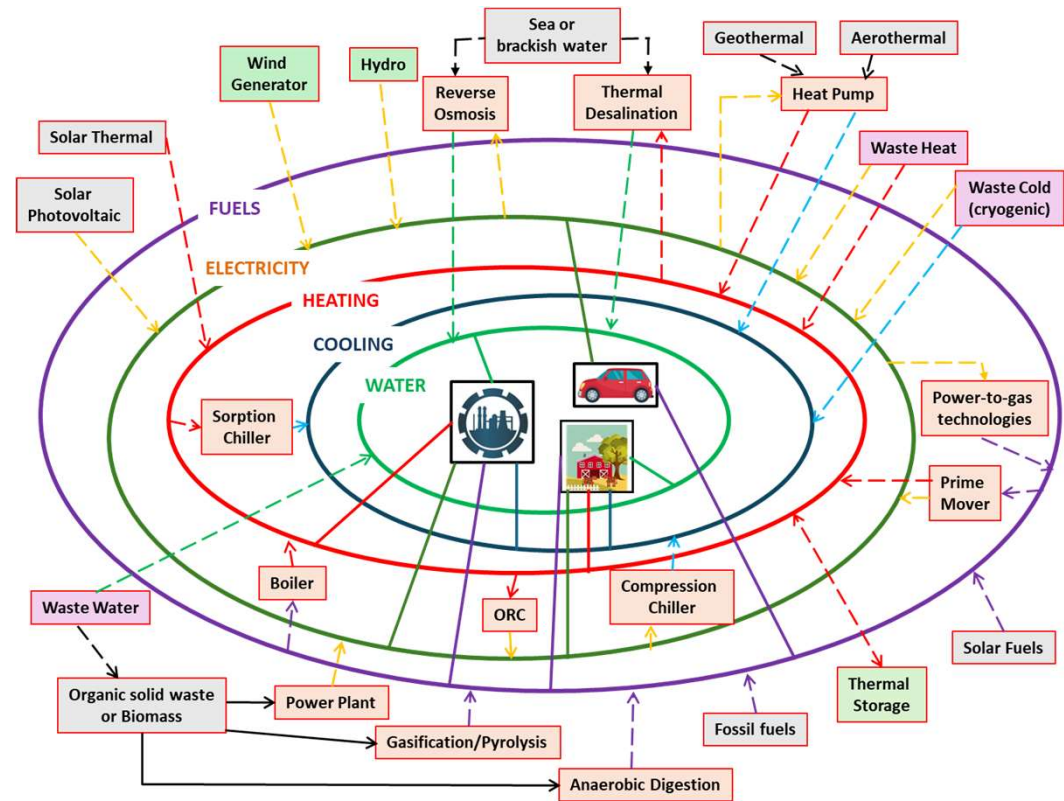

Techno-economic analysis of integrated biomass gasification and alkaline electrolysis for 5th generation district energy networks in Quebec, Canada Barco Burgos, J., Bruno, J.C., Ganesan, A., ... Colombo, J., Ortiz Valdez, C.I., Energy, 2025, 335, 138236

10 – Conclusions

Lignocellulosic biomass is considered one of the most promising renewable energy resources:

1. Abundant, widely available and dispatchable energy source.
2. Low net carbon emissions
3. Utilizes waste or low value subproducts reducing environmental burden
4. Versatile conversion pathways
5. Supports rural economies

Thermochemical conversion technologies provide not only energy services such as electricity and heat but also renewable fuels for decarbonizing sectors difficult to electrify and an alternative to electricity for mobility applications.

Integration of thermochemical technologies with other renewable energies in polygeneration systems increase energy efficiency by synergy effect between technologies and increase economic viability increasing the potential presence of renewable energies in the market.

Acknowledgements

Organitza:



amb la col·laboració de:



amb el suport de:



New polygeneration system for the production of heating and cooling and flexible storage of energy based on metal hydrides.

Ministerio de Ciencia e Innovación; FPI-Ajudes per a contractes predoctorals per a la formació de doctors. Any 2025 Proyecto: PID2024-160300OB-100

